

PRESSURE REGULATOR

DIVAL



DIVAL 160 - 250



DIVAL 50-75 - 100-125

TECHNICAL MANUAL MT036

INSTALLATION, COMMISSIONING AND MAINTENANCE INSTRUCTIONS

DIVAL

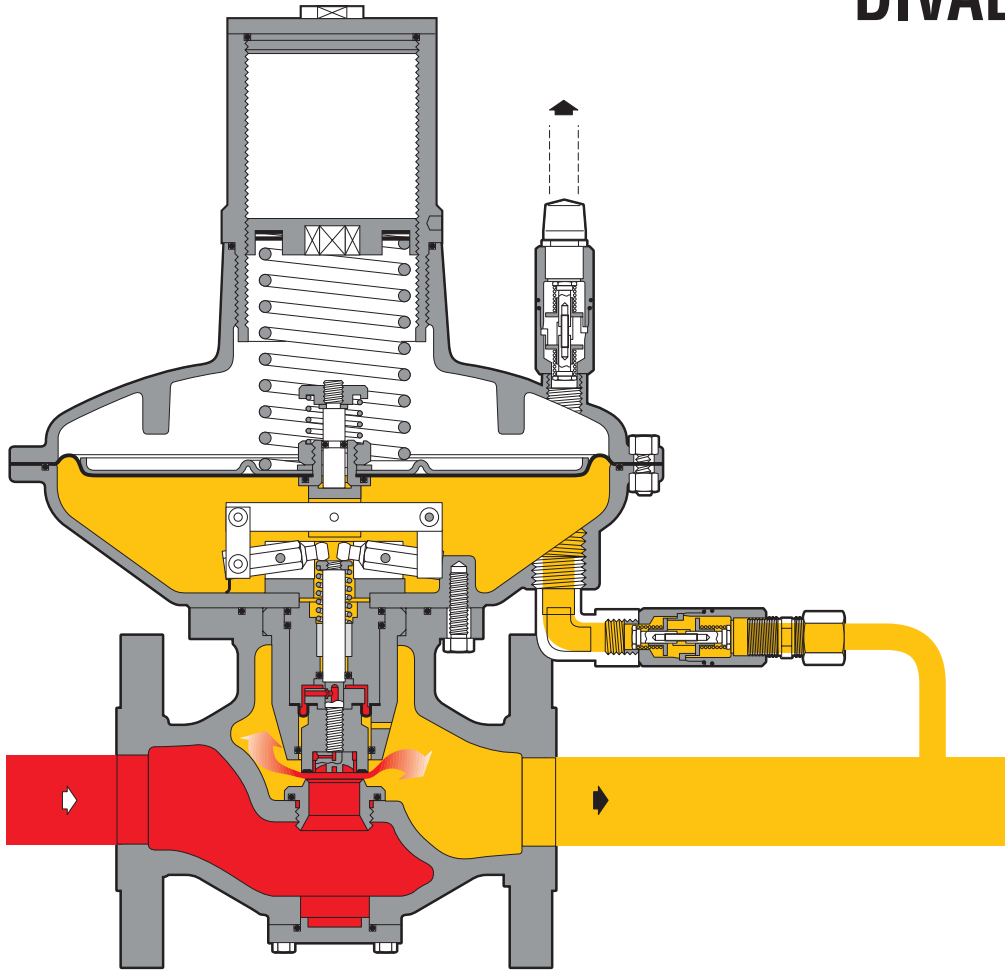

160-250

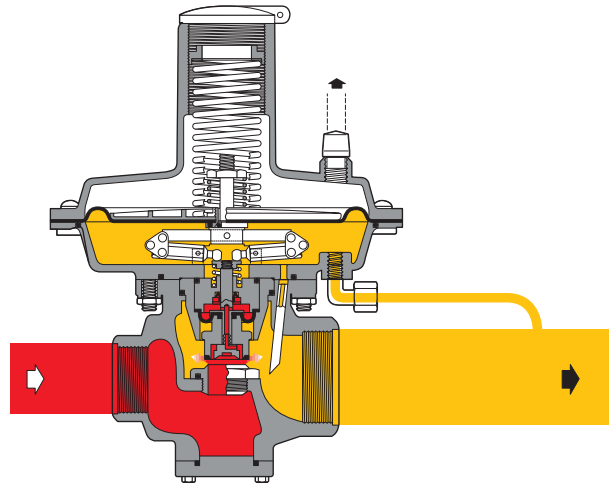

50-75 - 100-125

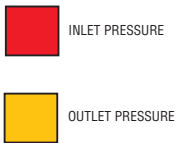

DECLARATION OF CONFORMITY

The **PIETRO FIORENTINI SPA** with registered office in Milan (Italy) – via Rosellini, 1, declares under its sole responsibility that the apparatus series Dival bearing the CE marking showed in this manual are designed, manufactured, tested and inspected in accordance with the provisions of Pressure Equipment Directive 97/23/EC (PED).

Following conformity assessment procedure has been carried out:

- EC type-examination (module B) by DVGW (ID n° 0085) – report **02/193/4301/850 issued 3rd June 2002** for Dival 160-250 and **02/201/4301/850 issued 11th June 2002** for Dival 50-75-100-125. In this report both the versions incorporating the safety shut-off devices series when controlling overpressure and in-line monitor system which includes a Dival with the function of active regulator and a 2° Dival with the function of in-line monitor, are classified as safety accessories according to clause 2.1.3 of art. 1 of PED.
- Production quality assurance (module D) by BUREAU VERITAS (ID n° 0062) – Attestation d'Approbation du Système Qualité N° **CE-PED-D-FI0001-02-ITA issued 15th May 2002.**

Further it declares that the classification of the performances characteristics has been verified by DVGW according to the procedures given by European standard EN 334 and/or by standard DIN 3381. The classification is detailed in the aforesaid DVGW report.

Arcugnano 25/9/2002

The Pietro Fiorentini SpA

PRECAUTIONS

GENERAL PRECAUTIONS

- The apparatus described in this manual is a device subject to pressure installed in systems under pressure;
- the apparatus in question is normally installed in systems for transporting flammable gases (natural gas, for example).

PRECAUTIONS FOR THE OPERATORS

Before proceeding with installation, commissioning or maintenance, operators must:

- examine the **safety provisions** applicable to the installation in which they must work;
- obtain the **authorisations** necessary for working when so required;
- use the necessary means of **individual protection** (helmet, goggles, etc.);
- ensure that the area in which they operate is fitted with the means of **collective protection** envisaged and with the necessary **safety indications**.

HANDLING

The handling of the apparatus and of its components must only be carried out after ensuring that the lifting gear is adequate for the **loads to lift** (lifting capacity and functionality). The apparatus must be handled using the **lifting points** provided on the apparatus itself.

Motorised means must only be used by the persons in charge of them.

PACKING

The packing for transportation of equipment and of relevant spare parts are designed and shaped to avoid damage to any part during transportation, warehousing and handling activities. Therefore the equipment and spare parts shall be kept into their packing until their installation in the final site. After packing is open, check that no damage occurred to any goods. If damage occurred inform the supplier and keep packing for any verification.

INSTALLATION

If the installation of the apparatus requires the application of **compression fittings** in the field, these must be installed following the **instructions of the manufacturer** of the fittings themselves. The choice of the fitting must be compatible with the use specified for the apparatus and with the specifications of the system when envisaged.

COMMISSIONING

Commissioning must be carried out by adequately trained personnel.

During the commissioning activities, the personnel not strictly necessary must be ordered away and the no-go area must be properly signalled (signs, barriers, etc.).

Check that the settings of the apparatus are those requested; if necessary, reset them to the required values in accordance with the procedures indicated in the manual.

When commissioning, the risks associated with any discharges into the atmosphere of flammable or noxious gases must be assessed.

In installations in natural gas distribution networks, the risk of the formation of explosive mixtures (gas/air) inside the piping must be considered.

CONFORMITY TO DIRECTIVE 97/23/EC (PED)

Pressure regulator Dival is classified as fail open regulator according to the standard EN 334 therefore it is categorized as **pressure accessory** according to directive 97/23/EC (PED).

The safety device in-line monitor is categorized as **safety accessory** according PED. The regulator Dival when incorporating slam shut valve with pressure switche for overpressure is categorized as safety accessory according to PED, therefore it can be used both as pressure accessory and **safety accessory** to PED.

Conformity with Directive 97/23/EC and CE marking of pressure regulator and relevant accessory require installation in the system with minimum requirements according to: EN 12286.

INDEX

1.0	INTRODUCTION	PAGE 9
1.1	MAIN FEATURES	9
1.2	DIVAL 160-250 OPERATION	9
1.2.1	DIVAL 50-100 OPERATION	12
1.3	REGULATOR SETTING SPRINGS	13
2.0	INSTALLATION	14
2.1	GENERAL	14
3.0	ACCESSORIES	17
3.1	RELIEF VALVE	17
3.1.1	DIRECT INSTALLATION IN THE LINE	18
3.1.2	INSTALLATION WITH ON/OFF VALVE	18
4.0	MODULARITY	19
4.1	LA/..INCORPORATED SLAM-SHUT	19
4.2	SLAM-SHUT SETTING SPRINGS	21
4.3	DIVAL FUNCTIONING AS A MONITOR	22
4.3.1	CHARACTERISTIC	22
4.3.2	DIVAL OPERATION WITH MONITOR FUNCTIONS	22
5.0	START UP	24
5.1	GENERAL	24
5.2	GAS INPUT, CONTROL OF EXTERNAL TIGHTNESS AND SETTING	26
5.3	COMISSIONING THE REGULATOR	26
5.4	COMMISSIONING THE REGULATOR WITH INCORPORATED LA/.. SLAM-SHUT	27
5.5	COMMISSIONING THE REGULATOR PLUS DIVAL IN-LINE MONITOR WITH INCORPORATED LA/.. SLAM-SHUT VALVE	31
6.0	TROUBLE-SHOOTING	34
6.1	REGULATOR	34
6.2	LA/.. SLAM-SHUT	35
7.0	MAINTENANCE	36
7.1	GENERAL	36
7.2	DIVAL REGULATOR MAINTENANCE PROCEDURE	37
7.2.1	DIVAL 160-250 REGULATOR	37
7.2.2	DIVAL 50-100 REGULATOR	39
7.2.3	L/.. SLAM-SHUT	40
8.0	FINAL OPERATIONS	41
8.1	THIGHTNESS AND SETTING CHECKS	41
8.2	START UP	41
9.0	LIST OF RECOMMENDED SPARES	43

1.0 INTRODUCTION

The scope of this manual is to provide the essential information for the installation, commissioning, disassembly, re-assembly and maintenance of DIVAL regulators.

It is also appropriate to provide a brief illustration of the main features of the regulator and of its accessories.

1.1 MAIN FEATURES

The DIVAL pressure regulator is a pressure regulator for previously cleaned gaseous fluids and is suitable for medium and low pressures.

The DIVAL is a normally open regulator and consequently opens in the event of:

- breakage of the main diaphragm;
- no regulated pressure signal;

The main specifications of this regulator are:

- design pressure: up to 18.9 bar;
- operating temperature range: -10 °C to +60 °C;
- ambient temperature: -20 °C to +60 °C;
- inlet pressure range bpe:
 - 0.1 to 5 bar for DIVAL 50-75 - 100-125;
 - 0.1 to 8 bar for DIVAL 160 and 250 BP;
 - 0.2 to 18 bar for DIVAL 160 and 250 MP-TR;
- possible regulation range Wh:
 - 0.01 to 3 bar for DIVAL 50-75 - 100-125;
 - 0.01 to 4 bar for DIVAL 160 and 250;
- minimum differential pressure: 0.1 bar;
- precision class RG: up to 5;
- closing pressure class SG: up to 10.

1.2 DIVAL 160-250 OPERATION (FIG. 1)

In the absence of pressure, the obturator 3 is maintained in the open position by the spring 43 (fig. 1).

The pressure downstream P_a is controlled by means of the comparison between the load of the spring 43 and the thrust which the downstream pressure itself exerts on the diaphragm 19. Also involved in this comparison are the weight of the mobile assembly, the thrust deriving from the spring 42 and the dynamic forces on the obturator.

The pressure upstream, even if variable, has no influence on the equilibrium of the obturator 3, as, because of the presence of the hole A, this finds itself between two equal pressures acting on equal surfaces. The movement of the diaphragm 19 is transmitted by the lever system 13 to the stem 9 and hence to the obturator 3. The function of the spring 41 is to annul all the inevitable play of the linkage system 13. The obturator is fitted with a vulcanized rubber gasket to ensure perfect tightness with zero flowrate demand.

If, during operation, the downstream pressure drops, the force it exerts on the diaphragm 19 becomes lower than the load of the spring 43. The diaphragm therefore drops and, by means of the lever system 13, pulls the obturator 3 away from the valve seat 2. The gas flow therefore increases until the initial pressure set-point is restored.

If, on the other hand, the downstream pressure begins to increase, the force exerted on the diaphragm 19 exceeds the load of the spring 43. The obturator is therefore displaced towards the closed position, returning the downstream pressure to the set-point.

In normal working conditions, the obturator 3 is positioned in such a way as to maintain the pressure P_a around the selected set-point.

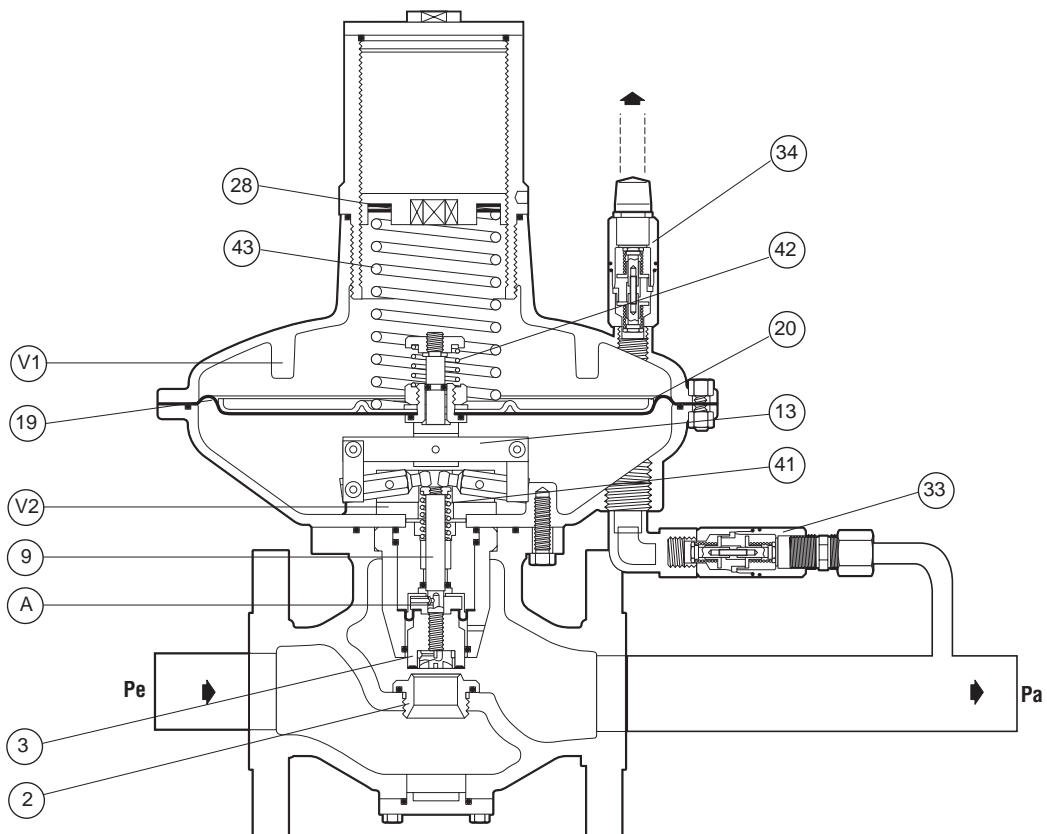

Fig. 1

To adjust the pressure set-point you can turn the internal adjustment ring 28 appropriately, clockwise to increase and anticlockwise to reduce it. Normally the plug is only used to cover the lower band of the various setting ranges; the adjusting screw is used for the higher values.

Versions 160 and 250 are provided with two antipumping devices 33 and 34 (fig. 1) whose function is to slow down the gas/air inflow/outflow in the head during the transitory phases only, to prevent possible phenomena of oscillation in the regulated pressure.

There are also two stops V1 and V2 for the purpose of eliminating damaging effects which could derive from accidental over-pressures below the diaphragm 19 or from overloading of the diaphragm 43.

A solution of the type shown in figure 2a is normally used in these versions so as to protect the obturator from damage deriving from sudden increases in the regulated pressure.

This solution permits the diaphragm protection disc 20 to rest against the top stop V1, overcoming the load of the spring 42, thereby relieving the obturator from the load caused by sudden pressure increases.

To prevent small leaks at zero flow demand or sudden and temporary over pressures resulting from fast operation or gas overheating, for example - from operating the slam-shut, the solution in fig. 2a can be transformed on request into an incorporated relief valve, eliminating the O-ring 73 and introducing the ring 70 (fig. 2b).

It works as follows: with the regulator closed, any over-pressures raise the diaphragm protection disc 20, overcoming the load of the springs 42 and 43.

In this way, a certain quantity of gas is discharged through the seat Z of the relief valve.

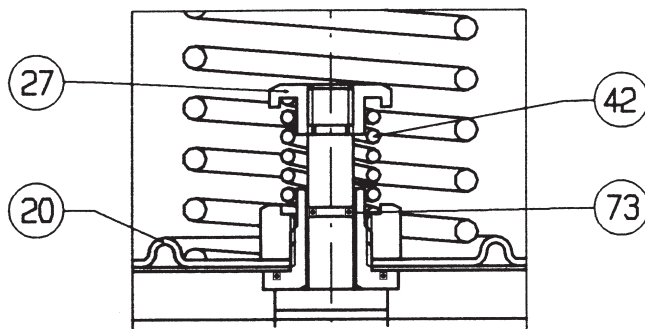

(Fig. 2a)

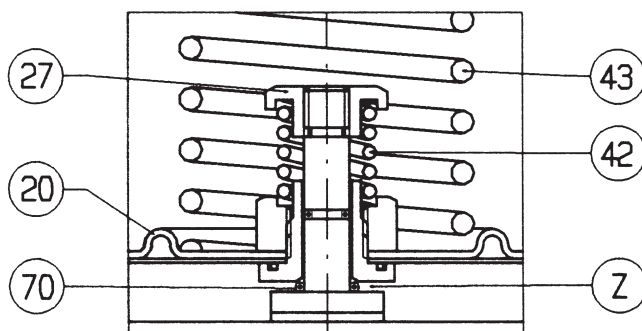

(Fig. 2b)

The set point of the relief valve can be varied by turning the nut 27 (clockwise to increase, vice-versa to decrease). The possible settings are shown in table 1.

Tab. 1

Pas= regulator setting pressure

Relief valve setting ranges (spring 42) for Dival 160 and 250						
Code	d	De	Lo	Setting range (mbar)		Head
				Min.	Max.	
2700645	2.3	22	40	(Pas x 1.05) +10		275BP
2700776*	2.5	22	40	(Pas x 1.05) +9	(Pas x 1.05) +26	275BP
2700999	3	22	37	(Pas x 0.96) +83	Pas +160	275MP-195

* on request

1.2.1 DIVAL 50-75 - 100-125 OPERATION (FIG. 3)

The operating principle of the Dival series 50-75 and 100-125 is completely similar to that of the series 160 and 250. What was explained in paragraph 1.1 is therefore also valid for them, with reference to fig. 3.

An antipumping device 34 is also provided for these versions. There is also an incorporated relief valve which is normally active (fig. 4b) but which can be deactivated when required by particular needs by in-serting the O-ring 73 (fig. 4a). Unless otherwise indicated, the relief valve is set $3 \div 7\%$ lower than the maximum slam-shut setting.

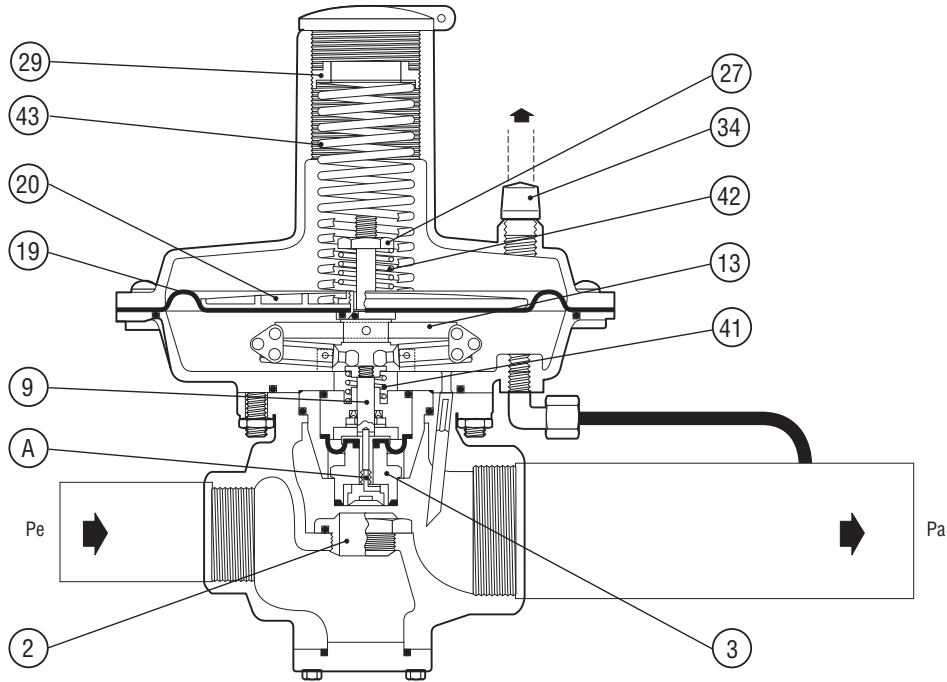
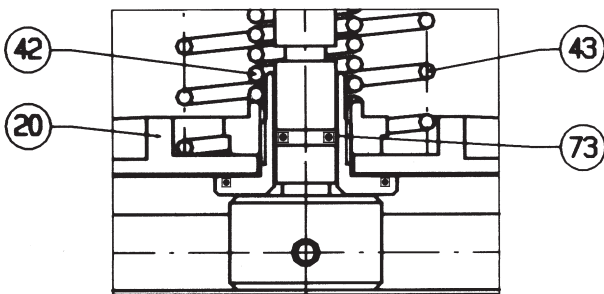
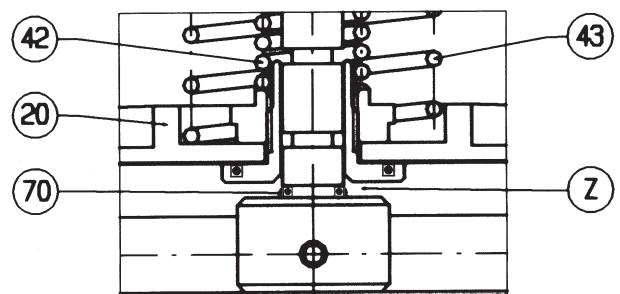

Fig. 3



(Fig. 4a)



(Fig. 4b)

1.3 Tab. 2 SETTING SPRINGS

Table 2 gives the possible settings ranges of the different versions.

Springs characteristics							DIVAL 160 - 250					
Code	Colour	De	Lo	d	i	it	SETTING RANGE in mbar				Head	
							DIVAL 250		DIVAL 160		BP	MP
2701175	WHITE	65	180	3.2	10	12	16 ÷ 22		10 ÷ 16	275		
2701345	YELLOW		180	3.5	10	12	20 ÷ 27		13 ÷ 21			
2701620	ORANGE		180	4	9.75	11.75	28 ÷ 39		20 ÷ 33			
2701860	RED		180	4.5	9.5	11.5	38 ÷ 59		30 ÷ 53			
2702190	GREEN		180	5	9.25	11.25	55 ÷ 80		48 ÷ 72			
2702370	BLACK		180	5.5	9	11	74 ÷ 120		68 ÷ 110			
2702540	BLUE		180	6	8.75	10.75	110 ÷ 190		100 ÷ 170	195	MP	
2702950	BROWN		180	7	8.5	10.5	180 ÷ 300		160 ÷ 280			
2703135	VIOLET		180	7.5	8	10	280 ÷ 320		260 ÷ 320			
2702940	LIGHT BLUE		150	7	6.5	8.5		310 ÷ 600				
2703125	WHITE-YELLOW		150	7.5	6.5	8.5		580 ÷ 900				
2703325	WHITE-ORANGE		150	8	7	9		880 ÷ 1200				
2703685	WHITE-GREEN		150	9	6	8		1100 ÷ 1950				
2703995	WHITE-BLACK		150	10	6.25	8.25		1900 ÷ 4000				

Springs characteristics							DIVAL 50-75 - 100-125					
Code	Colour	De	Lo	d	i	it	SETTING RANGE in mbar				Head	
							BP	MP	TR			
2700496	WHITE	34	115	1.8	12	15 ÷ 20				BP		
2700561	YELLOW		115	2	11.5	20 ÷ 30						
2700631	LIGHT BLUE		115	2.2	11.5	30 ÷ 40						
2700907	RED		115	2.7	12	40 ÷ 70						
2700974	GREEN		115	2.8	11	70 ÷ 110						
2700974	GREEN		115	2.8	11	80 ÷ 110	MP					
2701141	BLUE		115	3.2	11.5	110 ÷ 180						
2701394	ORANGE		100	3.8	10.5	180 ÷ 300						
2701886	BLACK		97	4.6	12.5	300 ÷ 700	TR					
2702060	GREY		100	5	10.5	700 ÷ 1100						
2702275	WHITE-GREEN		100	5.5	10	1100 ÷ 2000						
2702644	RED-BLACK		100	6.5	10.25	2000 ÷ 3000						

De = Ø external diameter

d = Ø wire diameter

i = active coils

Lo = Length

it = total coils

2.0 INSTALLATION

2.1 GENERAL

Pressure regulator does not require any supplementary upstream safety accessory for protection against overpressure compared with its design pressure PS, when upstream reducing station is sized for a max downstream incidental pressure $MIPd \leq 1,1 PS$.

Before installing the regulator it is necessary to ensure that:

- the regulator can be inserted in the space provided and that subsequent maintenance operations will be sufficiently practicable;
- the upstream and downstream piping is at the same level and capable of supporting the weight of the regulator;
- the inlet/outlet flanges of the piping are parallel;
- the inlet/outlet flanges of the regulator are clean and the regulator itself has not been subject to damage during transport;
- the piping upstream has been cleaned to expel residual impurities such as welding scale, sand, paint residues, water, etc.

The normally recommended set-up is:

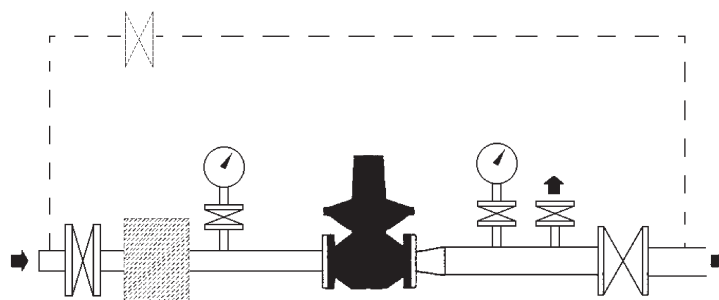

Fig. 5 Standard Regulator

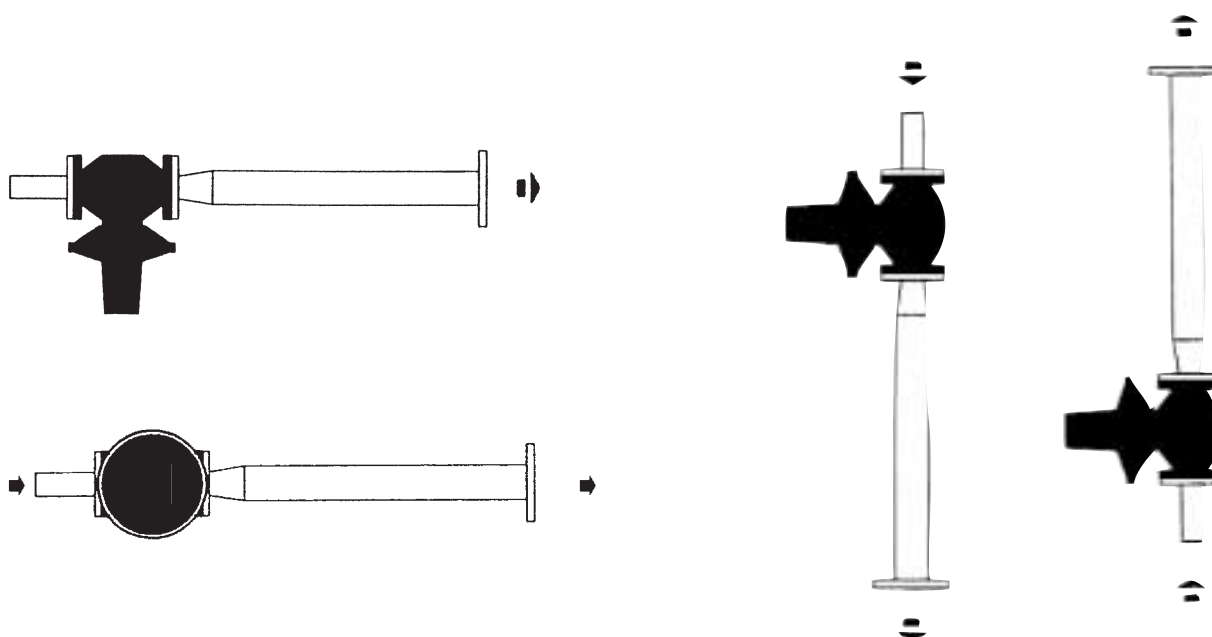
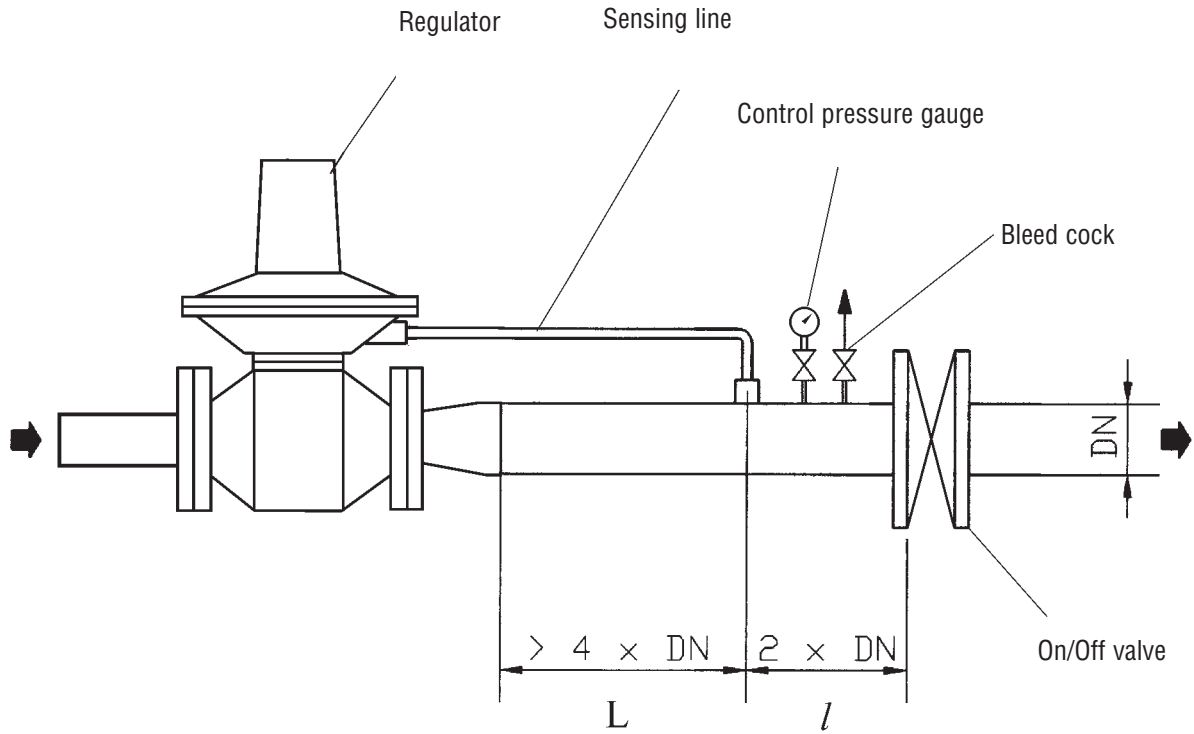

Fig. 6 Other possibilities

Tab. 3 CONNECTING THE APPARATUSES

The connections between the apparatus and the main piping must be made using stainless steel or cooper pipe with minimum internal diameter of 8 mm. for Dival 50-75 - 100-125 and 12 mm for Dival 160-250.

IN-LINE INSTALLATION



INSTALLATION AT RIGHT ANGLES

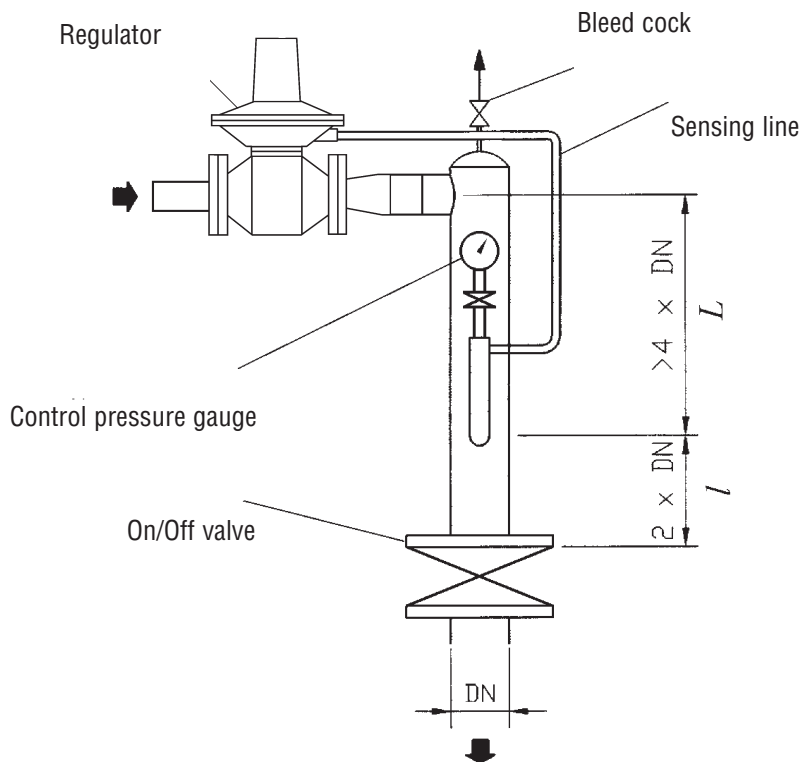

Tab. 4 DETAIL OF MULTIPLE TAKE-OFF

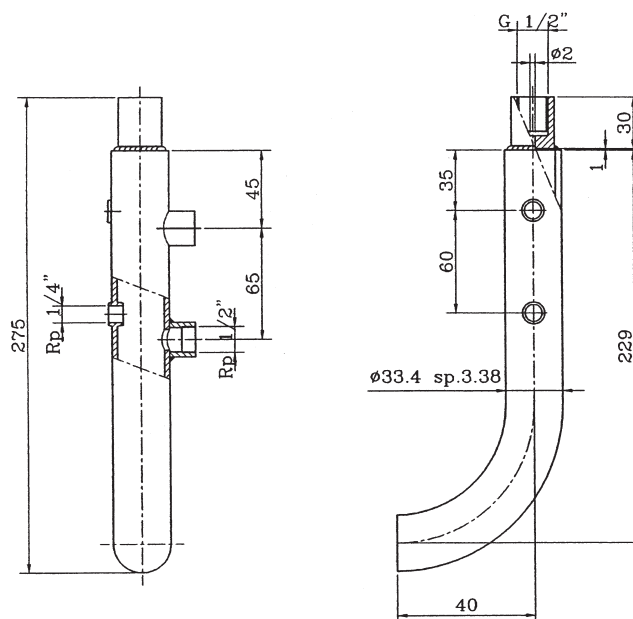

The regulator must be installed in the line **with the arrow on the body pointing in the gas flow direction**. It is indispensable for good regulation for the position of the downstream pressure take-offs and the speed of the gas at the take-off point to respect the values given in tables 3 and 4 (positioning) and 5 (speed). The pressure regulator, when installed on a reducing station, shall be installed at least according to the requirements of standard EN 12186.

All venting connections shall be connected as required by above mentioned standard. The following is recommended so as to prevent the accumulation of impurities and condensate in the lines of the pressure take-offs:

- a) the lines themselves must slope down towards the downstream piping with a slope of about 5-10%;
- b) the connectors on the piping must always be welded on the top of the piping itself and there must be no burr or inward protrusions in the hole in the piping.

NB. WE RECOMMEND NOT TO PUT ON/OFF VALVES ON THE IMPULSE TAKE-OFFS

Tab. 5

<p>The speed of the gas must not exceed the following values in the piping downstream from the regulator:</p> <p style="margin-left: 40px;">$V_{max} = 25 \text{ m/s}$ for $1,5 < Pa < 4 \text{ bar}$</p> <p style="margin-left: 40px;">$V_{max} = 20 \text{ m/s}$ for $0,5 < Pa < 1,5 \text{ bar}$</p> <p style="margin-left: 40px;">$V_{max} = 15 \text{ m/s}$ for $Pa < 0,5 \text{ bar}$</p>

DOWNSTREAM VOLUME REQUIRED FOR INSTALLATION

In the case of a service regulator of the ON-OFF type (stopping or starting of burners), you should remember that though the DIVAL apparatus is classified as being of the fast reaction type, it requires an appropriately dimensioned volume of gas between the apparatus itself and the burner so as to partly absorb the pressure swings caused by fast flow rate variations.

3.0 ACCESSORIES

3.1 RELIEF VALVE

The relief valve is a safety device which releases a certain quantity of gas to the exterior when the pressure at the control point exceeds the set-point as a result of short-lasting events such as, for example, the very fast closing of the on/off valves and/or overheating of the gas with zero flow rate demand. The release of the gas to the exterior can, for example, delay or block the intervention of the slam-shut valves for transitory reasons deriving from damage to the regulator.

Obviously the quantity of gas released depends on the extent of the overpressure with respect to the set-point. The different models of relief valves available are all based on the same operating principle which is illustrated below with reference to the valve VS/AM 55 (fig. 7).

It is based on the contrast between the thrust on the diaphragm 24 deriving from the pressure of the gas to control and the thrust from the setting spring 20. The weight of the mobile assembly, the static thrust and the residual dynamic thrust on the obturator 4 also contribute to this contrast. When the thrust deriving from the pressure of the gas exceeds that of the setting spring, the obturator 4 is raised and a certain quantity of gas is released as a result.

As soon as the pressure drops below the set-point, the obturator returns to the closed position. Proceed as indicated below to control and adjust intervention of the relief valve.

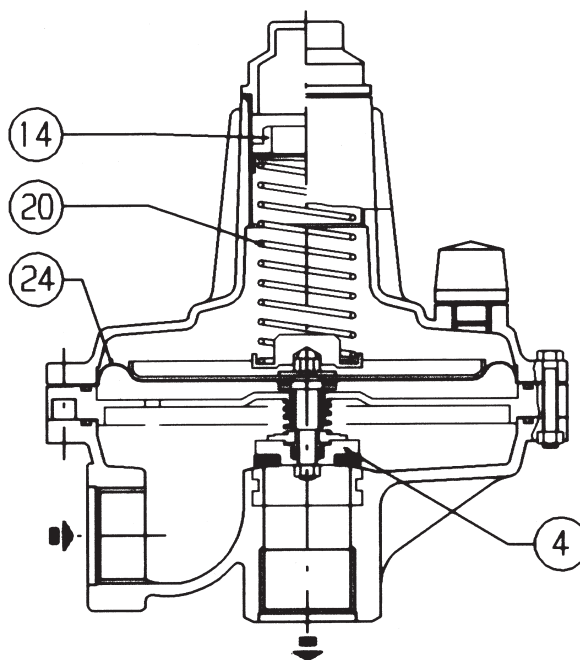

Fig. 7

3.1.1 DIRECT INSTALLATION IN THE LINE (Fig. 8)

When the relief valve is fitted directly in the line that is, without the interposition of an on/off valve, we recommend proceeding as follows:

- 1) ensure that the downstream on/off valve V2 and the bleed cock 6 are closed;
- 2) increase the pressure in the downstream section to the value at which intervention should occur by connecting a controlled auxiliary pressure to the cock 6 and stabilise it at the desired value;
- 3) check intervention of the relief valve and adjust it if necessary by turning the internal adjustment ring 14 appropriately (clockwise to increase the set-point, anticlockwise to reduce it).

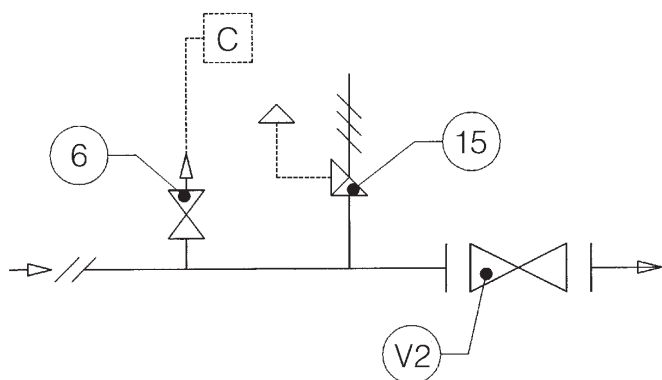

Fig. 8

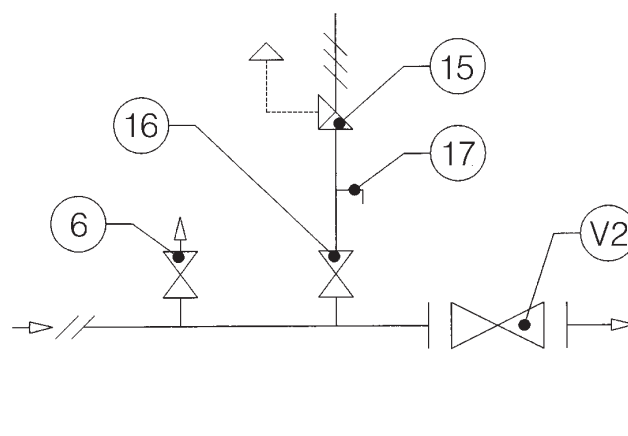

Fig. 9

3.1.2 INSTALLATION WITH ON/OFF VALVE (Fig. 9)

- 1) Close the on/off valve 16;
- 2) connect a controlled auxiliary pressure to the take-off 17 and increase it slowly to the envisaged intervention value;
- 3) check the intervention of the relief valve and adjust it if necessary by turning the internal adjustment ring 14 appropriately (clockwise to increase the set-point, anticlockwise to reduce it).

4.0 MODULARITY

The modular-type conception of DIVAL series regulators means that it is also possible to fit the slam-shut incorporated with the body itself even after the installation of the regulator.

Furthermore, the regulator can be adapted for operation as an in-line monitor by installing a special device.

4.1 LA/.. INCORPORATED SLAM-SHUT

This is a device (fig. 10-11) which immediately blocks the gas flow if, because of some failure, the downstream pressure reaches the point set for its intervention, or if it is actuated manually (Dival 160 and 250 only).

With the DIVAL pressure regulator, the slam-shut can be incorporated on both the service regulator or on the in-line monitor. Three versions (LA/BP, LA/MP and LA/TR) are available depending on the intervention pressure ranges.

The main features of the slam-shut device are as follows:

- cover design pressure: 18 bar;
- intervention for pressure increase and/or decrease;
- intervention accuracy AG: slam-shut L/BP: $\pm 10\%$ of the set point for pressure increases; $\pm 30\%$ of the set point for pressure drops;
- slam-shut L/MP-L/TR: $\pm 5\%$ of the set point for pressure increases; $\pm 15\%$ of the set point for pressure drops;
- internal by-pass device;
- manual button-operated actuating device

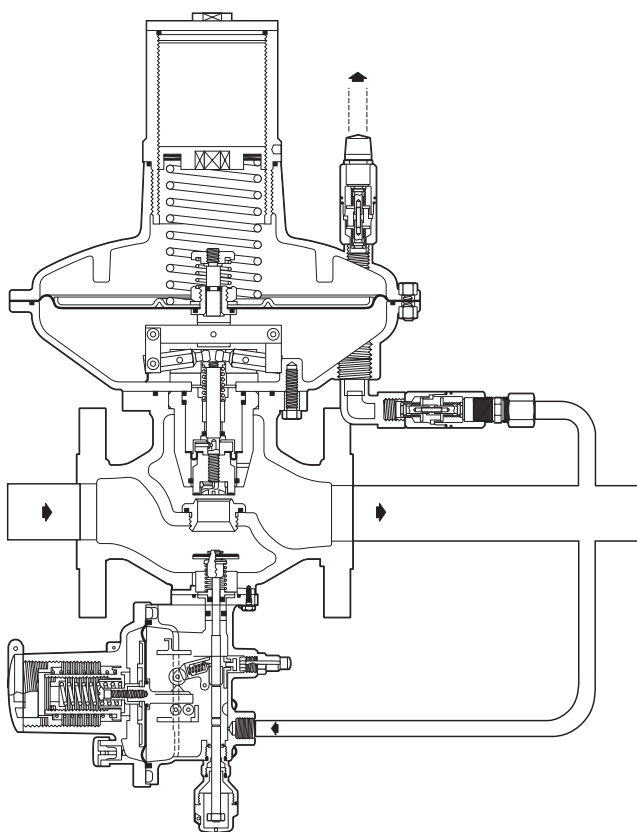

Fig. 10
Dival 160-250 + LA/..

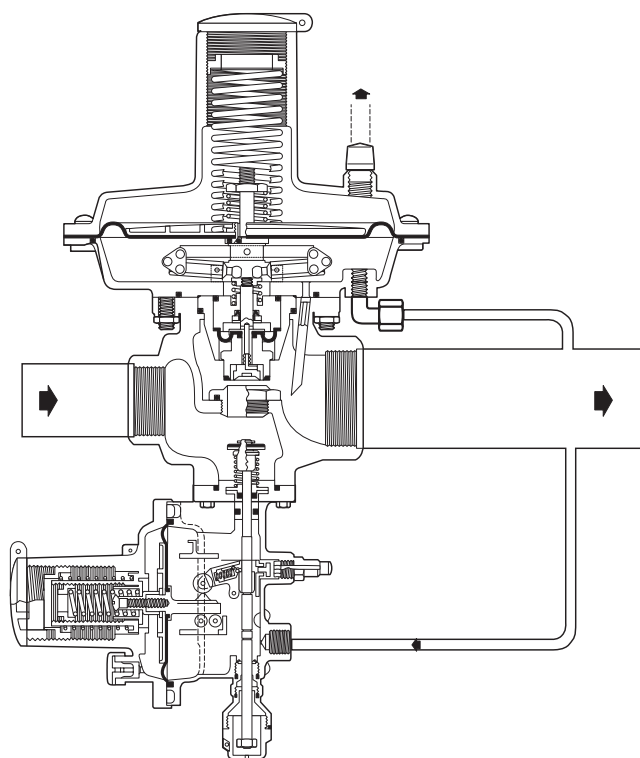
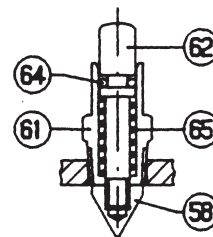
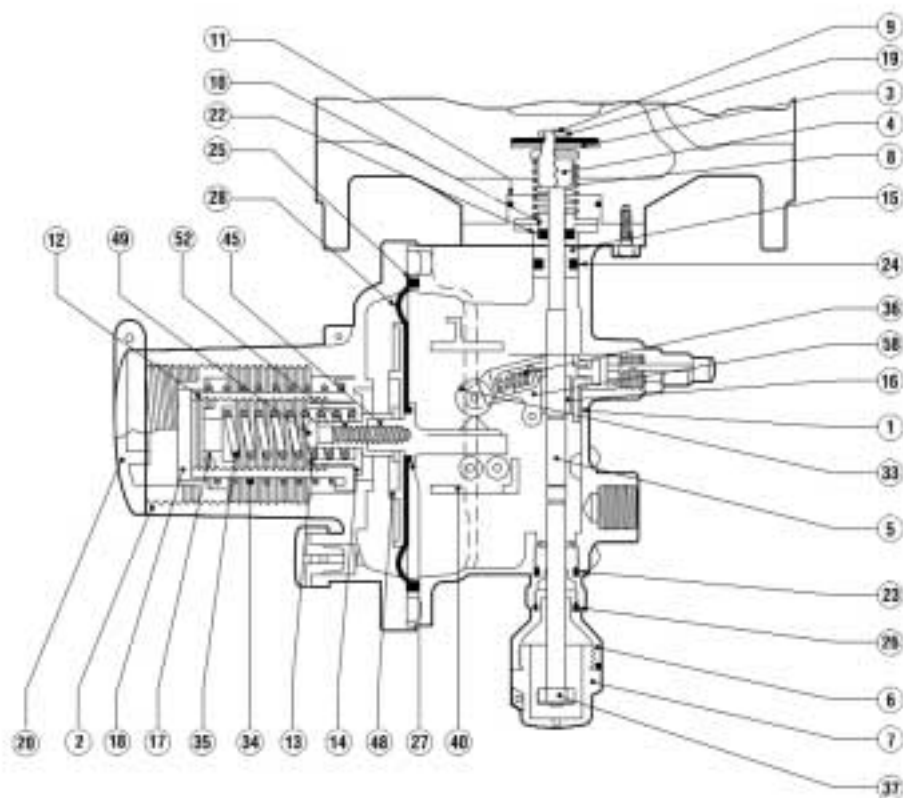

Fig. 11
Dival 50-75 - 100-125 + LA/..



Detail of manual button operated actuating device

Note: the O-ring 25 is used for particular versions

Fig. 11

The slam-shut valve LA/.. consists essentially of an obturator (fig. 11) fitted on a stem, a releasing lever system, a control head and a manual resetting system.

The pressure to control P_a , in chamber C of the control head, acts on the diaphragm 46 which is integral with the cam shaft 45.

The load of the pressure P_a on the diaphragm is countered by the springs 34 and 35 which respectively determine intervention for pressure increase and pressure decrease.

The device is set by turning the rings 17 and 18. Turning the rings clockwise increases the intervention value; turning anticlockwise decreases it. Intervention as a result of a pressure increase occurs as follows: when the pressure P_a exceeds the set point the load on the diaphragm 46 increases until it overcomes the resistance of the spring 34.

This causes the shaft 45 to translate towards the left so that the cam shifts the feeler 33 and trips the lever mechanism 29. In this way, the stem 5 with the obturator 19 is freed and closed by the spring 8.

On the other hand, intervention as a result of a pressure decrease occurs as follows: as long as the pressure P_a stays above the load of the spring 35, the spring support 13 rests on the support 12.

If the pressure P_a drops below the set point, the spring 35 translates the support 13 to the right and with it the shaft 45.

The cam shifts the feeler 33 and trips the lever mechanism 29. The slam-shut is reset by unscrewing the threaded bushing 7 and pulling it downwards until the lever system 29 is reset.

During the first phase of the operation, it will be necessary to wait until the upstream pressure, through the internal by-pass, passes downstream from the obturator to rebalance it. After resetting, the bushing 7 must be screwed back to its seat.

It is possible to see from the outside whether the slam-shut is open or closed by observing the position of the nut 37 through in the bushing 7, as shown in figure 11.

Table 6 lists the range of intervention of the pressure switches available.

4.2 Tab. 6 LA/... SLAM-SHUT SETTING SPRINGS

Springs characteristics							SLAM SHUT LA/BP/MP	
Code	Colour	De	Lo	d	i	it	SETTING RANGE in mbar	
							Intervention for max pressure	
2700632	WHITE	34	43	2,2	5,5	7,5	30	÷ 60
2700912	YELLOW		46	2,8	5	7	60	÷ 180
							Intervention for min pressure	
2700327	WHITE	15	45	1,3	6,5	8,5	6	÷ 60
							Intervention for max pressure	
2701143	ORANGE	34	40	3,2	4,5	6,5	180	÷ 280
2701139	RED		50	3,2	4,5	6,5	280	÷ 450
							Intervention for min pressure	
2700514	YELLOW	15	40	2	6,75	8,75	60	÷ 240

							SLAM SHUT LA/TR	
							Intervention for max pressure	
2701143	ORANGE	34	40	3,2	4,5	6,5	250	÷ 550
2701139	RED		50	3,2	4,5	6,5	550	÷ 850
2701246	BLACK		50	3,5	5	7	850	÷ 1500
2701522	BLUE		50	4	4	6	1500	÷ 2500
2701775	VIOLET		50	4,5	4,5	6,5	2500	÷ 4000
2702064	LIGHT BLUE		50	5	4	6	4000	÷ 5500
							Intervention for min pressure	
2700514	YELLOW	15	40	2	6,75	8,75	100	÷ 600
2700989	ORANGE		40	3	6,5	8,5	600	÷ 2000
2701185	RED		43	3,2	7,5	9,5	2000	÷ 3500

De = Ø external diameter **d** = Ø wire diameter **i** = active coils **Lo** = Length **it** = total coils

4.3 DIVAL FUNCTIONING AS A MONITOR

The monitor is an emergency regulator whose function is to come into service instead of the main regulator when failure of the latter causes the downstream pressure to reach the point set for monitor intervention. PIETRO FIORENTINI has a solution for this emergency device for in-line installations.

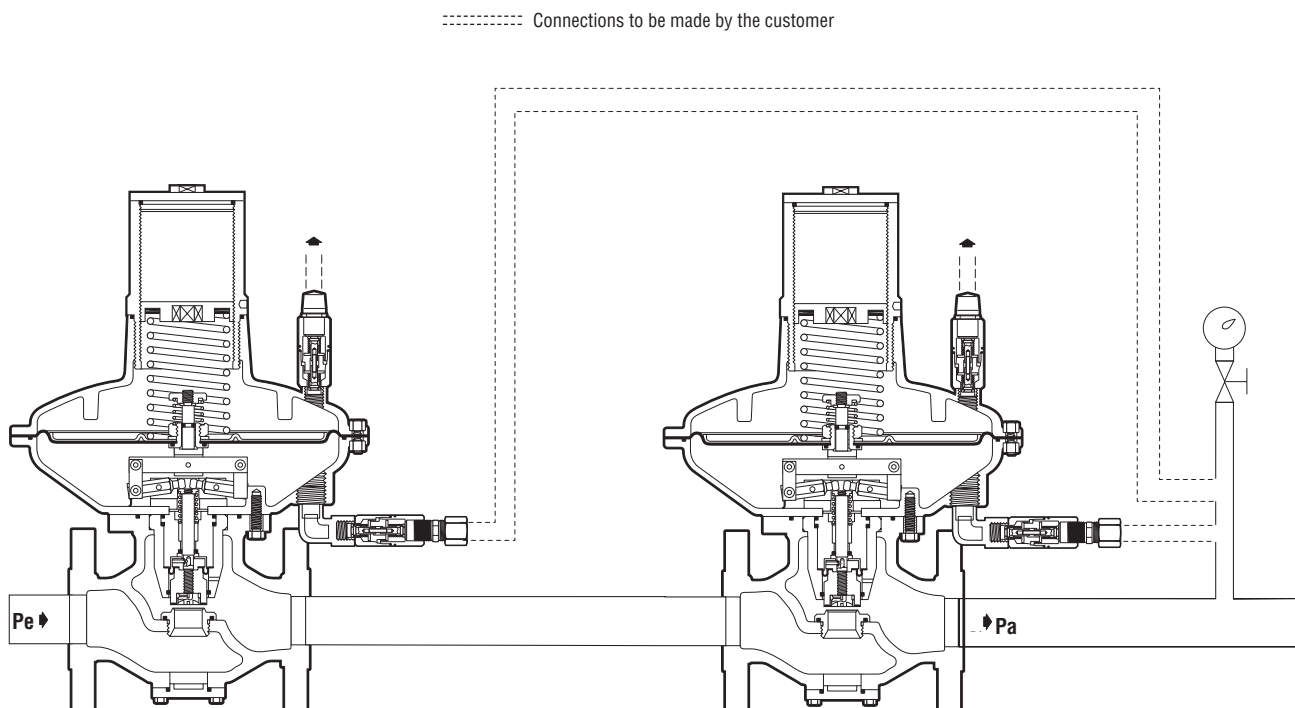

Fig. 12

4.3.1 CHARACTERISTICS

- Reduced dimensions;
- Easy maintenance;
- Can also be mounted on a normal regulator already installed.

4.3.2 DIVAL OPERATION WITH MONITOR FUNCTIONS

The DIVAL with monitor functions is a regulator which, compared with the normal version, has a further mobile assembly balancing device which guarantees greater precision in the regulated pressure and therefore an equally precise pressure intervention value without problems of interference with the main regulator. In this configuration, the monitor regulator has a construction variation which is illustrated in fig. 13a for sizes 160 and 250.

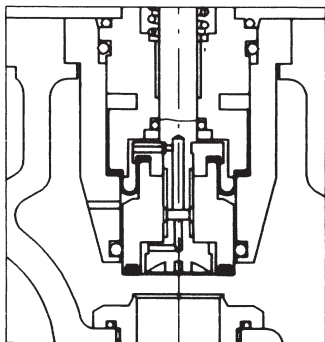

Fig. 13a
STANDARD REGULATOR

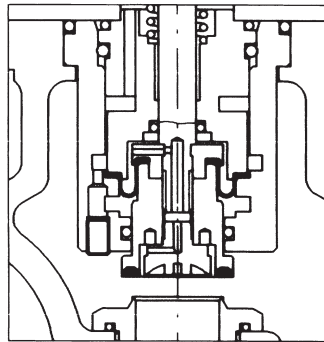

Fig. 13a
MONITOR REGULATOR

Fig. 13b shows the variation relating to sizes 50-100. The variations consists in the blocking of the hole of the internal impulse take-off by means of the plug 5 and the insertion of the O-ring 68.

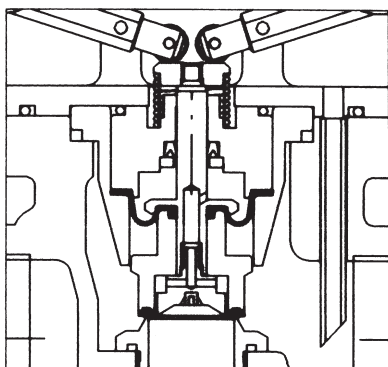

Fig. 13b
STANDARD REGULATOR

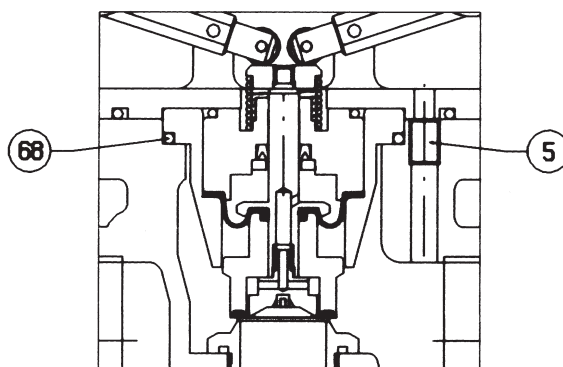

Fig. 13b
MONITOR REGULATOR



5.0 START UP



5.1 GENERAL

After installation, check that the inlet/outlet on/off valves, any by-pass and the bleed cock are closed. Before commissioning, you must ensure that the conditions of use comply with the characteristics of the apparatuses.

These characteristics are recalled by the symbols on the specification plates applied to each apparatus. We recommend actuating the opening and closing valves very slowly. The regulator could be damaged by operations which are too fast. It is to be noted that pressure regulators with monitoring functions are identified on the plate by the letters "DIVAL/M".

APPARATUS SPECIFICATION PLATES

	Pietro Fiorentini		ID n.0062	
REGULATOR	DIVAL 250G	T:		
S.n.:		PS:		Pemax: <input type="text"/> bar
DN:		Flange:	<input type="text"/>	AC: <input type="checkbox"/>
Wh:		Bpe:	<input type="text"/> bar	SG: <input type="checkbox"/>
Wa:		Fluido:	METANO	Cg: <input type="checkbox"/>

	Pietro Fiorentini
SLAM SHUT DEVICE:	LA/TR-250
S.n.:	<input type="text"/> Who: <input type="text"/> bar
T:	<input type="text"/> Wao: <input type="text"/> bar
AG:	<input type="text"/> Whu: <input type="text"/> bar
AG:	<input type="text"/> Wau: <input type="text"/> bar
	

Regolatore tipo DIVAL	50/BP
DNe 1"DNu <input type="text"/>	N°Fabb. <input type="text"/>
pzul <input type="text"/> bar pe <input type="text"/> bar pas <input type="text"/> mbar	
Blocco tipo L/	BP
min <input type="text"/> mbar	max <input type="text"/> mbar

The list of symbols used and their meanings are listed below:

CE= Conformity to PED Directive

P_{max}= maximum operating pressure at the inlet of the apparatus

b_{pe}= range of variability of the inlet pressure of the pressure regulator in normal operating conditions

PS= massima pressione che può essere sopportata in condizioni di sicurezza dalla struttura del corpo dell'apparecchio

W_a= setting range of the pressure regulator/ pilot/pre-regulator which can be obtained using the parts and the setting spring fitted at the moment of testing (that is without changing any components of the apparatus). In piloted regulators, the pilot is considered as a separate apparatus with its own setting range W_a

W_h= setting range of the pressure regulator/pilot/ pre-regulator which can be obtained using the setting springs indicated in the associated tables and also by changing some other part of the apparatus (reinforced gasket, diaphragm etc.). In piloted regulators, the pilot is considered as a separate apparatus with its own setting range W_h

Q_{maxP_{emin}}= maximum flow rate with minimum pressure at the pressure regulator inlet

Q_{maxP_{max}}= maximum flow rate with maximum pressure at the pressure regulator inlet

C_g= experimental coefficient of critical flow

RC= regulation class

SG= closing pressure class

AG= intervention accuracy

W_{ao}= range of intervention for the over pressure of slam-shut, relief and safety valves and accelerators which can be obtained using the setting spring fitted at the moment of testing. In piloted safety valves, the pilot is considered as a separate apparatus with its own setting range W_{ao}

W_{ho}= range of intervention for the over pressure of slam-shut, relief and safety valves and accelerators which can be obtained using the setting springs indicated in the tables. In piloted safety valves, the pilot is considered as a separate apparatus with its own setting range W_{ho}

W_{au}= range of intervention for pressure decrease of slam-shut which can be obtained using the setting spring fitted at the moment of testing

W_{hu}= range of intervention for pressure decrease of slam-shut which can be obtained using the setting springs indicated in the tables.

5.2 GAS INPUT, CONTROL OF EXTERNAL TIGHTNESS AND SETTING

The apparatus pressurization operation must be carried out very slowly. To protect the apparatus from damage, the following operations **must never be carried out**:

- **Pressurization through a valve located downstream from the apparatus itself.**
- **Depressurization through a valve located upstream from the apparatus itself.**

External tightness is guaranteed if no bubbles form when a foam medium is applied on the element under pressure. The regulator and any other apparatuses (slam-shut, monitor) are normally supplied already set for the desired set-point. It is possible for various reasons (e.g., vibration during transport) for the settings to be changed while remaining within the values permitted by the springs used.

We therefore recommend checking the settings using the procedures illustrated below.

Tables 7 and 8 give the recommended set-points for the apparatuses in the various installation arrangements. The figures in these tables can be useful both when checking existing set-points and for modifying them should this become necessary later.

In installations consisting of two lines, we suggest commissioning one line at a time, starting from the one with the lower set-point, known as the “reserve” line. **The set-points of the apparatuses in this line will obviously deviate from those specified in the tables 7 and 8.**

Before commissioning the regulator you must check that all the on/off valves (inlet, outlet, any by-pass) are closed and that the gas is at a temperature which will not lead to malfunction.

5.3 MESSA IN SERVIZIO DEL REGOLATORE

If there is also a relief valve in the line, refer to par. 3.1 to check it.

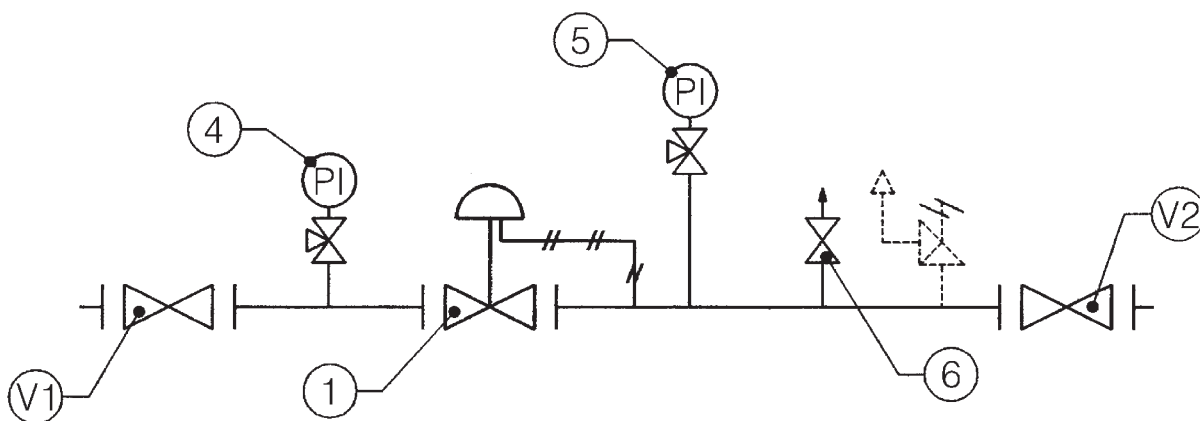

Fig. 14

- 1) very slowly open the inlet on/off valve V1;
- 2) check on the pressure gauge 5 that the pressure does not exceed the pre-established set-point, plus a tolerance of 10% due to the closing force of the regulator;
- 3) stabilise the upstream and downstream pressures and open the bleed cock 6;
- 4) check on the pressure gauge 5 that the downstream pressure is at the set-point. If it is not, adjust the setting by means of the provided internal ring (fig. 1), turning it clockwise to increase it and anticlockwise to decrease it;
- 5) close the bleed cock and check the pressure set-point;
- 6) check the tightness of all the joints between the on/off valves V1 and V2 using a foam solution;
- 7) very slowly open the downstream on/off valve V2, until the line is completely filled.

5.4 COMMISSIONING THE REGULATOR WITH INCORPORATED LA/.. SLAM-SHUT

If there is also a relief valve in the line, refer to par. 3.1 to check it.

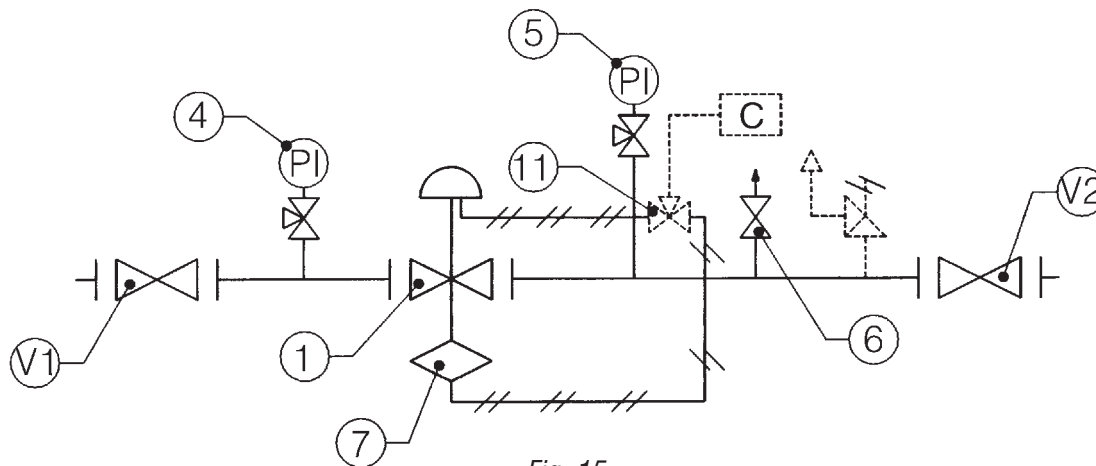
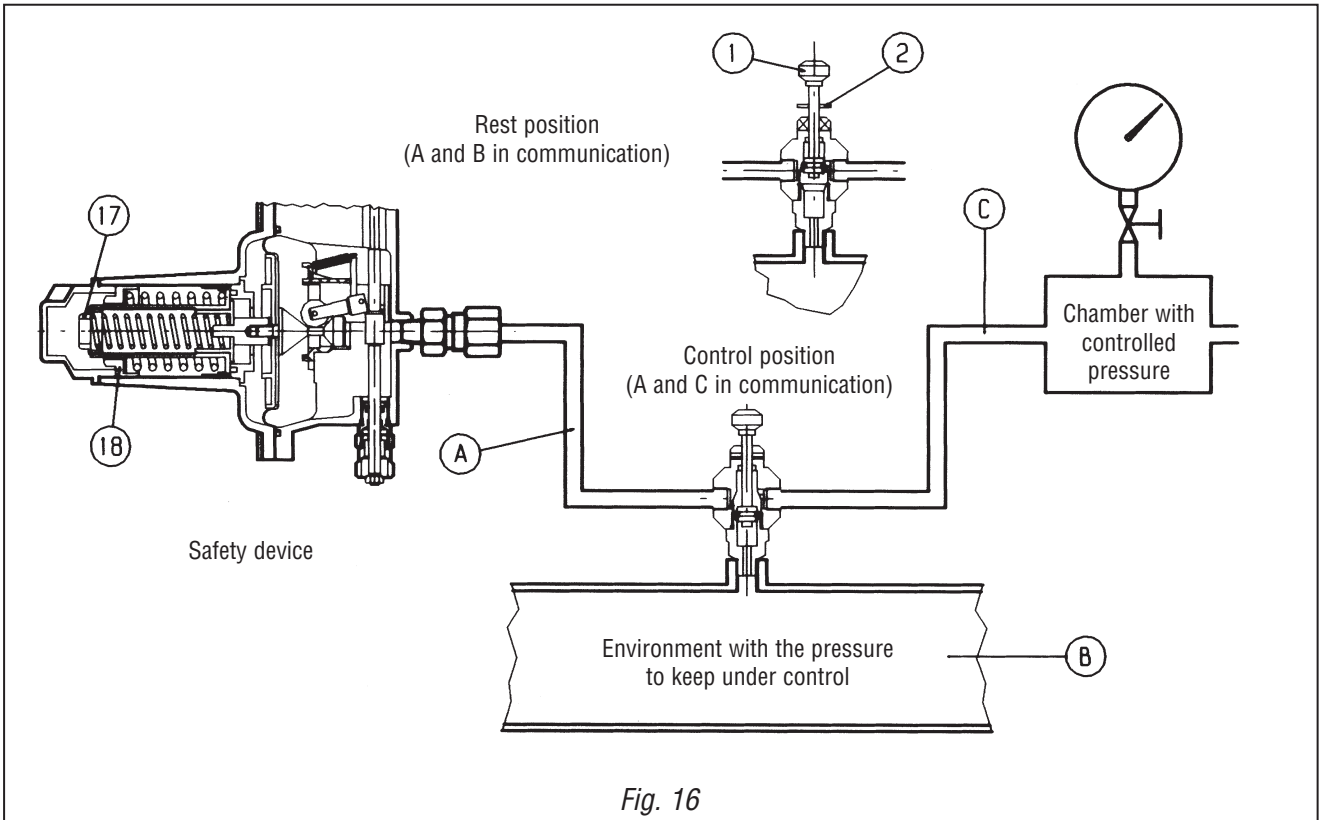

Fig. 15

Check and adjust the intervention of the slam-shut 7 as follows:

A) For slam-shuts connected to the downstream piping by a three-ways deviator push valve 11, proceed as follows (Fig. 16):

- connect a controlled auxiliary pressure to path C;
 - stabilise this pressure at the set-point established for the regulator;
 - insert a reference pin 2 in the notch, pressing the knob 1 completely;
 - reset the slam-shut device by means of the provided threaded bushing;
 - keep the knob 1 pressed and:
 - for safety devices which intervene for maximum pressure: slowly increase the auxiliary pressure and check the intervention value. If necessary, increase the intervention value by turning the adjustment ring 18 clockwise, or anticlockwise to reduce the intervention value.
 - for safety devices which intervene for pressure increase and reduction: slowly increase the auxiliary pressure and record the intervention value. Restore the pressure to the set-point established for the regulator, and carry out the slam-shut reset operation.
- Check intervention for pressure reduction by slowly reducing the auxiliary pressure.
- If necessary, increase the intervention values for pressure increase or decrease by respectively turning the rings 18 and 17 clockwise and vice versa to reduce them.
- check proper operation by repeating the operations at least 2-3 times.



B) On devices without the "push" valve (fig. 17) we recommend connecting the control head separately to a controlled auxiliary pressure and repeating the operations described above.

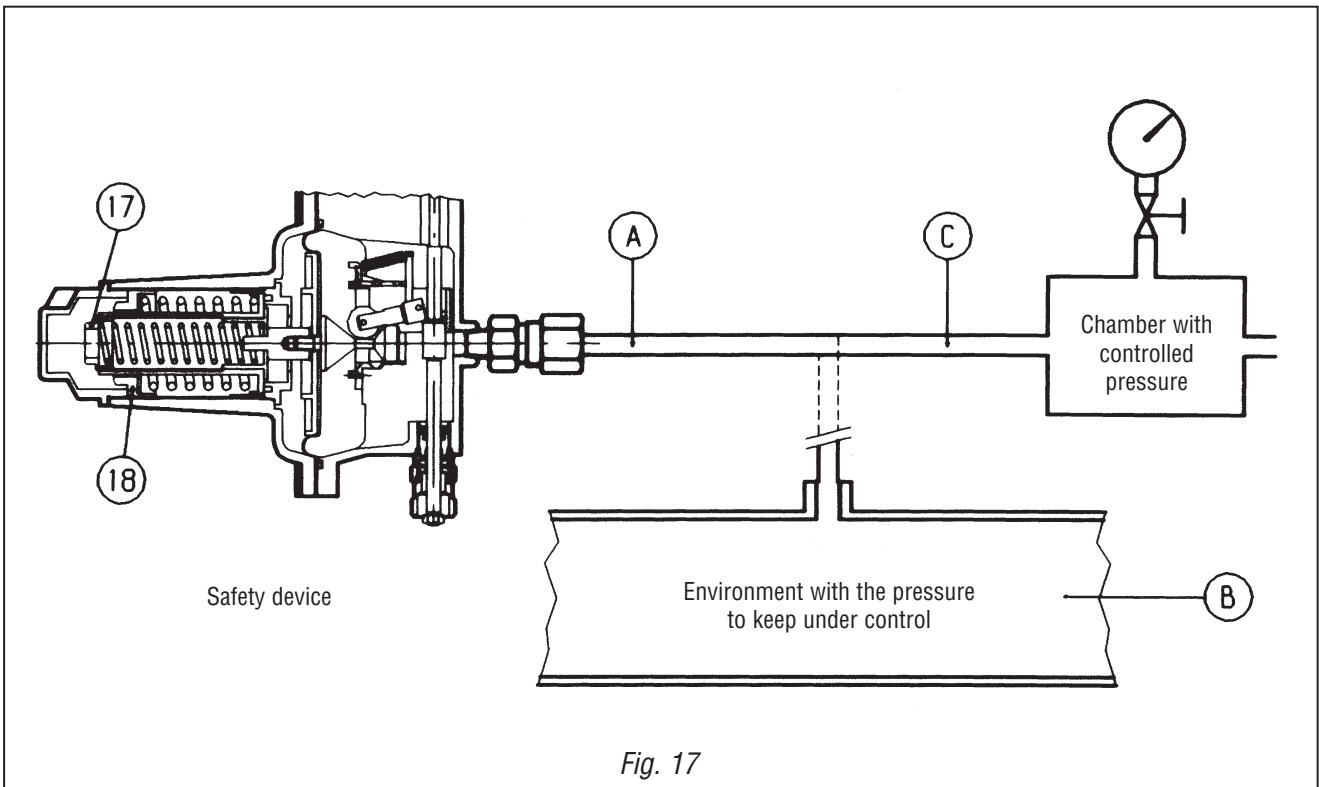

ATTENTION

At the end of the operation, reconnect the control head to the downstream pressure take-off.

N.B.: The intervention tests should be repeated at least every 6 months.

At the end of the slam-shut check, proceed as follows:

- 1) check that the slam-shut is in the closed position;
- 2) open the inlet on/off valve V1;
- 3) very slowly open the slam-shut by pulling the provided threaded bushing;
- 4) open the downstream bleed cock 6;
- 5) check on the pressure gauge 5 that the downstream pressure is at the desired regulator set-point. If it is not, adjust the setting by means of the provided internal ring, turning it clockwise to increase it and anticlockwise to decrease it;
- 6) close the bleed cock 6 and check the closing pressure value;
- 7) using a foam medium, check the tightness of all the joints between the on/off valves V1 and V2;
- 8) very slowly open the downstream on/off valve V2, until the line is completely filled;
- 9) check that when you operate the slam-shut manually, the flow in the line stops.

Tab. 7	Setting of on-line apparatuses consisting of regulator DIVAL + Slam shut + Relief valve		
Regulator set-point (Pas) mbar	RELIEF VALVE	SLAM-SHUT Max	SLAM-SHUT Min
10<Pas≤15	↑ Pas x 1.7 ↓	Slam-shut not available	Slam-shut not available
15<Pas≤19		↑ Pas x 2 ↓	↑ 10 mbar ↓
19<Pas≤24		↓	↑ Pas x 0.56 ↓
24<Pas≤35	↑ Pas x 1.55 ↓	↑ Pas x 1.77 ↓	↑ Pas x 0.57 ↓
35<Pas≤40		↑ Pas x 1.7 ↓	↑ Pas x 0.6 ↓
40<Pas≤70	↑ Pas x 1.4 ↓	↑ Pas x 1.52 ↓	
70<Pas≤80	↑ Pas x 1.3 ↓	↑ Pas x 1.4 ↓	
80<Pas≤100		↑ Pas x 1.46 ↓	
100<Pas≤750	↑ Pas x 1.16 ↓	↑ Pas x 1.5 ↓	↑ Pas x 0.7 ↓
750<Pas≤1000		↓	↓
1000<Pas≤2500		↑ Pas x 1.2 ↓	
2500<Pas≤4000	↓	↓	↓

5.5 COMMISSIONING THE REGULATOR PLUS DIVAL IN-LINE MONITOR WITH INCORPORATED LA/.. SLAM-SHUT VALVE

If there is also a relief valve in the line, refer to par. 3.1 to check it.

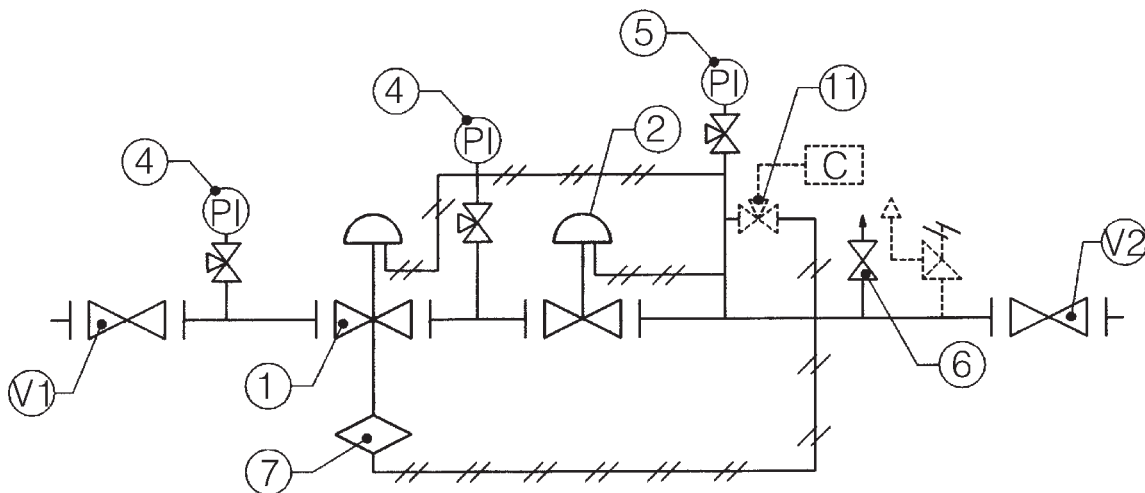

Fig. 18

Check and adjust the intervention of the slam-shut 7 as follows:

A) For slam-shuts connected to the downstream piping by a three-ways deviator push valve 11, proceed as follows (Fig. 16):

- connect a controlled auxiliary pressure to path C;
- stabilise this pressure at the set-point established for the regulator;
- insert a reference pin 2 in the notch, pressing the knob 1 completely;
- reset the slam-shut device by means of the provided threaded bushing;
- keep the knob 1 pressed and:
 - for safety devices which intervene for maximum pressure: slowly increase the auxiliary pressure and check the intervention value. If necessary, increase the intervention value by turning the adjustment ring 18 clockwise, or anticlockwise to reduce it.
 - for safety devices which intervene for pressure increase and reduction: slowly increase the auxiliary pressure and record the intervention value. Restore the pressure to the set-point established for the regulator, and carry out the slam-shut reset operation.
- Check intervention for pressure reduction by slowly reducing the auxiliary pressure. If necessary increase the intervention values for pressure increase or decrease by respectively turning the rings 18 or 17 clockwise and vice versa to reduce them.
- check proper operation by repeating the operations at least 2-3 times.

- B) On devices without the "push" valve (fig. 17) we recommend connecting the control head separately to a controlled auxiliary pressure and repeat the operations described above.

ATTENTION

At the end of the operation, reconnect the control head to the downstream pressure take-off.

N.B.: The intervention tests should be repeated at least every 6 months.

At the end of the slam-shut check, proceed as follows:

- 1) ensure that the slam-shut is in the closed position;
- 2) disconnect the sensing line of the main regulator 2 and appropriately plug the connection fitting on the downstream section;
- 3) very slowly open the on/off valve V1;
- 4) very slowly open the slam-shut by pulling the provided threaded bushing;
- 5) check on the pressure gauge 5 that the downstream pressure is at the set-point established for the monitor 1, taking account of the closing overpressure;
- 6) open the bleed cock 6;
- 7) check on the pressure gauge 5 that the downstream pressure has the established setting value. If it does not, adjust the setting by means of the special internal ring, turning it clockwise to increase its value and anticlockwise to it;
- 8) trip the slam-shut manually;
- 9) connect the sensing line of the main regulator;
- 10) very slowly open the slam-shut valve by turning the provided lever;
- 11) check on the pressure gauge 5 that the downstream pressure settles at the set-point established for the main regulator 2, taking account of the closing overpressure;
- 12) open the downstream bleed cock;
- 13) check on the pressure gauge 5 that the downstream pressure has the established setting value. If it does not, adjust the setting by means of the special internal ring, turning it clockwise to increase and anticlockwise to reduce;
- 14) close the bleed cock and check the value of the closing pressure;
- 15) check the tightness of all the joints between the on/off valves V1 and V2 using a foam medium;
- 16) very slowly open the downstream on/off valve V2, until the line is completely filled.
- 17) check that when you operate the slam-shut manually, the flow in the line stops.

Tab. 8	Setting of on-line apparatuses consisting of regulator DIVAL + Monitor + Slam Shut + Relief valve			
Regulator set-point (Pas) mbar	Set-point MONITOR	Set-point RELIEF VALVE	Set-point SLAM-SHUT Max	Set-point SLAM-SHUT Min
10 < Pas ≤ 15	↑ ↓	↑ ↓	Slam-shut not available	Slam-shut not available
15 < Pas ≤ 19			Pas x 1.7	10 mbar
19 < Pas ≤ 24			Pas x 1.7	Pas x 0.56
24 < Pas ≤ 35	Pas + 5 mbar	↑ ↓	Pas x 1.77	Pas x 0.57
35 < Pas ≤ 40	↑ ↓	Pas x 1.55	Pas x 1.7	↑ ↓
40 < Pas ≤ 70		Pas x 1.4	Pas x 1.52	
70 < Pas ≤ 80		Pas x 1.3	Pas x 1.4	
80 < Pas ≤ 100	↑ ↓	↑ ↓	Pas x 1.46	↑ ↓
100 < Pas ≤ 750		Pas x 1.15	Pas x 1.4	
750 < Pas ≤ 1000		Pas x 1.3	Pas x 1.46	
1000 < Pas ≤ 2500	↑ ↓	↑ ↓	Pas x 1.5	Pas x 0.7
2500 < Pas ≤ 4000	Pas x 1.07	Pas x 1.16	Pas x 1.2	↑ ↓

6.0 TROUBLE-SHOOTING

The problems of various kinds which could arise over time are highlighted below.

They derive from phenomena associated with the conditions of the gas as well, of course, as with the natural ageing and wear of the materials.

It must be remembered that all operations on the apparatuses must be carried out by highly qualified personnel with appropriate knowledge of the subject. Tampering with the apparatuses by unsuitable personnel relieves us from all responsibility of any kind.

You must therefore train your maintenance personnel or avail yourself of the service centres officially authorised by us.

6.1 Tab. 9 REGULATOR (FIG. 19 and 20)

INCONVENIENTE	CAUSE POSSIBILI	INTERVENTO
No tightness at Q=0	Valve seat 2 damaged	Replace
	Obturator 3 damaged	Replace
	O-ring 63 damaged	Replace
	O-ring 66 danneggiato	Sostituzione
	O-ring 76 damaged (only Dival 50-100)	Replace
	O-ring 67 damaged	Replace
	Diaphragm 6 damaged	Replace
	Dirt or foreign bodies in the seal area	Clean
Pumping	Anomalous friction of the rod-obturator assembly	Clean and, if necessary, replace sealing and/or guide elements
	Antipumping valves blockage	Clean and replace if necessary
	Reduced downstream volumes	Increase volume
Increase in Pa with Q>0	Diaphragm 19 breakage	Replace
	Diaphragm 6 breakage	Replace

6.2 Tab. 10 LA/... SLAM-SHUT (FIG. 21)

PROBLEM	POSSIBLE CAUSES	REMEDY
Slam-shut obturator does not close	Control head diaphragm [16] ruptured	Change the diaphragm
Leakage from slam-shut obturator	Obturator gasket [10] deteriorated	Change the gasket
	O-ring [66] worn	Change
	Obturator seat [7] eroded or pitted	Change the seat
Incorrect intervention pressure	Wrong setting of maximum and/or minimum spring	Make the setting again using the rings [12] and/or [13]
	Friction in lever systems	Change the box containing the whole assembly
Rearming not possible	Persistence of the cause which led to pressure increase or decrease downstream	Decrease or increase the downstream pressure
	Lever systems broken or chipped	Change the standard box containing the assembly outside the regulator

N.B. If the slam-shut has intervened, close the inlet and outlet valve (**V1** and **V2**) in the line and discharge the pressure before carrying out any operation.
Eliminate the causes which gave rise to intervention before reactivating it.

In the event of operating problems when personnel qualified for a specific operation are not available, call the service centre nearest to you. For further information contact our SATRI service centre at our Arcugnano (Vicenza) works.

7.0 MAINTENANCE

7.1 GENERAL

Periodical inspection and maintenance shall be carried out according to the regulations in force (kind and frequencies). Before carrying out any operation it is important to ascertain that the regulator has been cut off both upstream the regulator and the on/off valves.

The maintenance operations are closely associated with the quality of the gas transported (impurities, humidity, gasoline, corrosive substances) and with the efficiency of the filtering.

Preventive maintenance should be carried out at intervals which, if not established by regulations in force, depend on:

- the quality of the gas transported;
- the cleanliness and conservation of the piping upstream from the regulator: in general, for example, when starting the equipment for the first time, more frequent maintenance is required because of the precarious state of cleanliness inside the piping;
- the level of reliability required from the regulation system.

Before starting the disassembly operations on the apparatus you should check that:

- a set of recommended spares is available. The spares must be original **Fiorentini**  ones, bearing in mind that the more important ones such as diaphragms are marked
- A set of wrenches is available as specified in table 11.

For a proper maintenance the recommended spare parts are unequivocally identified by labels indicating:

- The No of assembly drawing SR of the apparatus for which the spare parts are suitable,
- The position showed in the assembly drawing SR of the apparatus

N.B. The use of non-original spare parts relieves us of all responsibilities.

In the maintenance is carried out by your own authorized personnel, we recommend putting reference markings, before the disassembly, on those parts which could have directional or reciprocal positioning problems when reassembling. Finally, we would remind you that O-Rings and sliding mechanical components (rods, etc.) must be lubricated, before the re-assembly, with a fine **layer** of silicone grease. Before recommissioning of equipment after maintenance, external tightness shall be verified at a proper to assure no external leakage. When equipment is used as safety accessory to PED, internal sealing at the maximum expected operating pressure. Both verifications are essential to assure safe use at foreseen operating conditions; they have, anyhow, to comply with the national regulations in force.

7.2 DIVAL REGULATOR MAINTENANCE PROCEDURE

Procedure for the disassembly, complete replacement of the spare parts and re-assembly of the DIVAL pressure regulator + LA (PROGRAMMED PREVENTIVE MAINTENANCE)

PRELIMINARY OPERATIONS

- A. Render the regulator safe;
- B. Ensure that the pressure upstream and downstream from it is 0.

DISASSEMBLY AND REASSEMBLY

7.2.1 DIVAL 160-250 REGULATOR (fig. 19).

- 1) Disconnect the connections between the regulator and the downstream pressure take-off and then unscrew the antipumping valves (33) and (34) from the head. Normally these do not require further disassembly unless, obviously, there are operating problems with them.
- 2) Completely unscrew and the plug (29) and the internal adjustment ring (28). Then remove the spring (43).
- 3) Remove the screws (46) to separate the head from the body (1).
- 4) Remove the screws (47) which hold the covers (17) and (18) together and remove the cover (18).
- 5) Slacken the part (27) and remove the spring (42).
- 6) Remove the diaphragm assembly and unscrew the nut (52) to disassemble the washer (24), the protection disc (20), the diaphragm (19) and the diaphragm support (22).
- 7) Remove the screws (49) which fix the lever assembly (13) to the cover (17), and remove the assembly itself without disassembling the components.
- 8) From the body (1) remove the balancing assembly consisting of the obturator guide (4) and the parts contained in it. Then press on the screw (12) to remove the other components from the obturator guide. (4)
- 9) In the case of the Dival 160 (fig. 19a), unscrew the screw (12) from the obturator (3); then slacken the rod (9) from the obturator (3), exploiting the nut glued to the rod and the flat faces on the obturator.
- 10) In the case of the Dival 250 (fig. 19b), the screw (12) and the rod (9) are fixed directly together; in this case too it is possible to use the faces of the nut glued on the rod to dismantle them.
- 11) Unscrew the valve seat (2) from the body, taking a lot of care not to damage the sealing edges.
- 12) Finally remove the screws (48) to disassemble the blank flange (10).

To reassemble the regulator it is possible to carry out the disassembly operations in the inverse order.

Before reassembling the sealing elements (O-rings, diaphragms, etc.), check their integrity and replace them if necessary. Take care that the diaphragm 6 is perfectly inserted in its housing and that there are no impediments to the movement of the rod-obturator assembly.

The maximum care must be taken when handling the valve seat (2) so as not to damage the sealing edges.

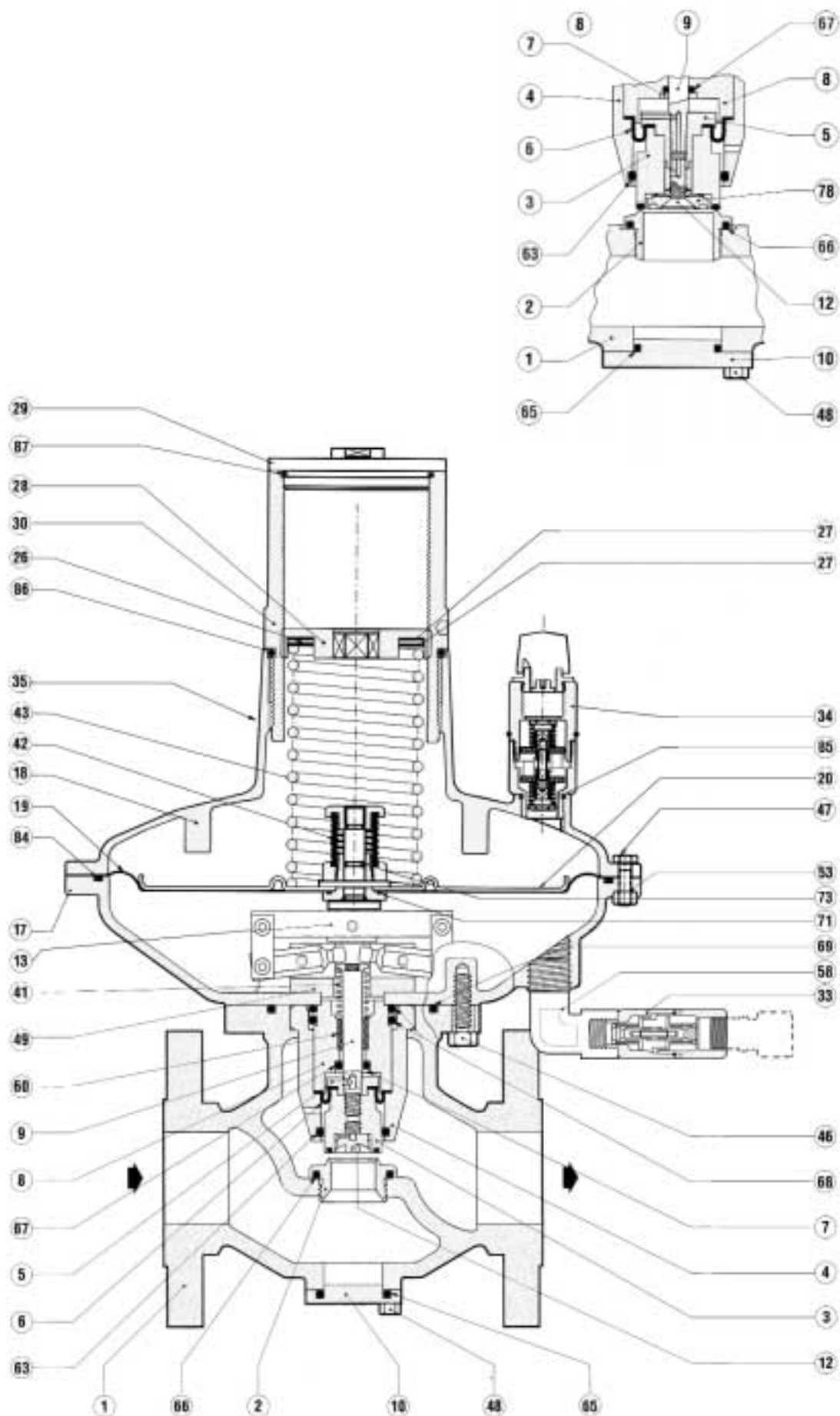

Fig. 19

7.2.2 DIVAL 50-75-100-125 REGULATOR (fig. 20)

- 1) Disconnect the connections between the regulator and the downstream pressure take-off.
- 2) Completely unscrew the adjustment ring (29) and the plug (30). Then remove the spring (43).
- 3) Remove the nuts (50) to separate the head from the body (1).
- 4) Remove the screws (47) which hold the covers (17) and (18) together.
- 5) Slacken the nut (27) and remove the spring (42).
- 6) Unscrew the ring (52) to remove the protection disc (20) and the diaphragm (19) from the diaphragm support (22).
- 7) Remove the screws (49) which fix the lever assembly (13) to the cover (17).
- 8) From the body (1), remove the balancing assembly consisting of the obturator guide (4) and the parts contained in it.
- 9) To disassemble the above components unscrew the nut (81) and the screw (12); in this way it is possible to disassemble the rod guide (8), the rod (9), the diaphragm (6) and the obturator (3).
- 10) Unscrew the valve seat (2) from the body, taking great care not to damage the sealing edges.
- 11) Finally remove the screws (48) to disassemble the blank flange (10).

To reassemble the regulator it is possible to carry out the disassembly operations in the inverse order, taking particular care with the orientation of the bottom cover (17), so that the internal impulse pipe (5) corresponds with the hole in the cover.

Before reassembling the sealing elements (O-rings, diaphragms, etc.), check their integrity and replace them if necessary. Take care that the diaphragm (6) is perfectly inserted in its housing and that there are no impediments to the movement of the rod-obturator assembly.

The maximum care must be taken when handling the valve seat (2) so as not to damage the sealing edges.

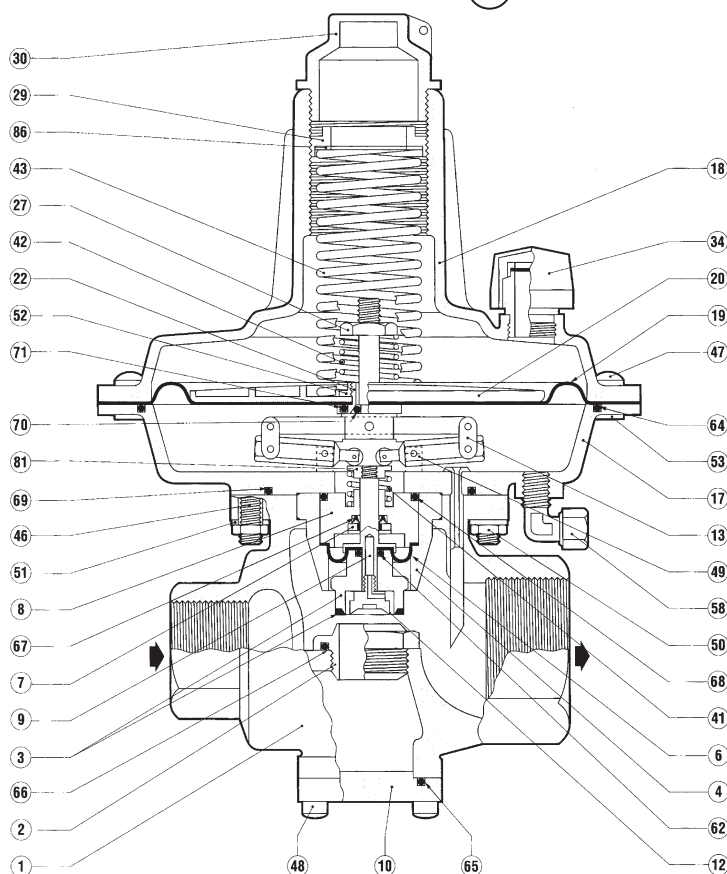

Fig. 20 Dival 50-75-100-125

7.2.3 LA/..SLAM-SHUT (fig. 21)

- 1) Ensure that the slam-shut is in the closed position.
 - 2) Disconnect the connection pipe from the fitting (47).
 - 3) Remove the screws which fix the slam-shut to the body.
 - 4) Completely unscrew the plug (20) and the adjusting rings (17) and (18), and then remove the setting springs (34) and (35) and the spring supports (12) and (13).
 - 5) Remove the screws (41) and disassemble the cover (2) with the ring (14).
 - 6) From the body (1) remove the diaphragm assembly consisting of the parts 45, 46, 48 and 49; to separate them unscrew the pin (45) from the fixing nut (49).
 - 7) Remove the screw (37) and completely unscrew the ring (6) and the threaded bushing (7).
 - 8) From the top remove the shaft assembly composed of parts 9, 66, 19, 4 and 8, the bushings (22) and (23) and the shaft (5). Then unscrew the obturator support (4) from the shaft (5) and remove the retaining ring (9) to disassemble the obturator (19).
 - 9) Remove the screws (40) and disassemble the anchoring assembly composed of the parts 29, 30, 33, 36, 38, 39, and 43.
 - 10) Remove the screws (53) to disassemble the flange (51).
 - 11) Finally, to disassemble the button release assembly, unscrew the nut (61) and then the part (58) from the pin (62).
- To reassemble the slam-shut it is possible to carry out the disassembly operations in the inverse order.
Before reassembling the sealing elements (O-rings, diaphragms, etc.), check their integrity and replace them if necessary.

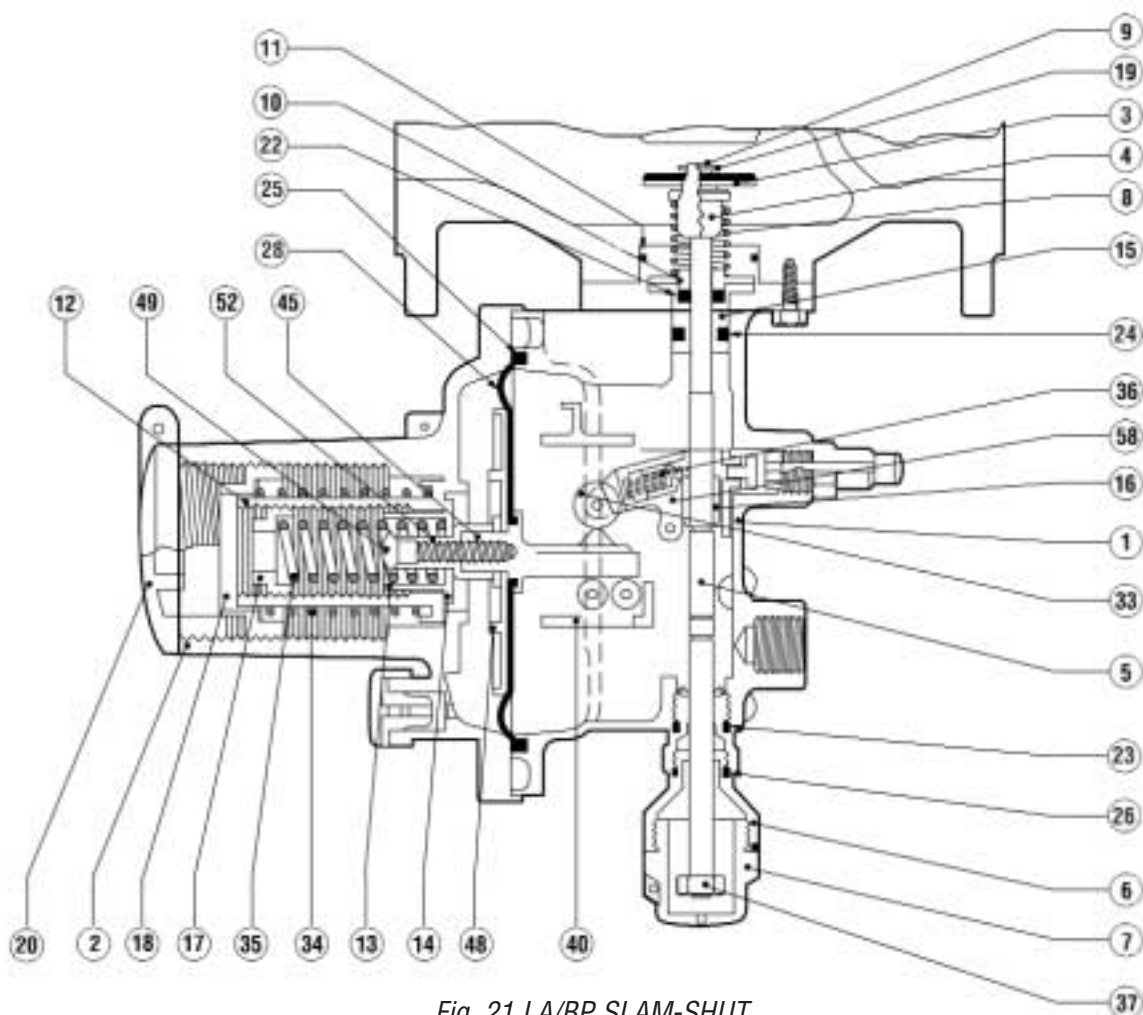

Fig. 21 LA/BP SLAM-SHUT

8.0 FINAL OPERATIONS













8.1 CHECKING THE TIGHTNESSES AND SETTING

- 1) Very slowly open the on/off valve upstream from the regulator and using a foam solution or the like check:
 - the tightness of the external surfaces of the regulator;
 - the tightness of the slam-shut;
 - the tightness of the internal surfaces of the regulator;
 - the tightness of the fittings.
- 2) Operating very slowly, pull the provided threaded bushing, pos. (7), of the slam-shut until only the internal by-pass is opened. Pull completely to the re-engage position.
 - Check the tightness of the reinforced gasket of the regulator.
- 3) Open a bleed cock downstream from the regulator to create a small gas flow.
- 4) Turn the internal adjustment ring pos. (29) until the desired set-point value is reached.
- 5) Close the bleed cock to the atmosphere.

8.2 START UP

- 1) Very slowly open the downstream on/off valve and, if necessary, adjust the regulator set-point by means of the internal adjustment ring, pos. (28) .

Tab. 11 MAINTENANCE WRENCHES FOR DIVAL (+ LA) PRESSURE REGULATORS

 (A) Combination spanner	 (B) Adjustable spanner	 (C) Compass pin wrench
 (D) Box spanner	 (E) Hexagon or allen key	 (F) Hexagonal Te key
 (G) Hexagonal socket T wrench	 (H) Philips screwdriver	 (I) Flat head screwdriver
 (L) O-Ring extraction tool	 (M) Circlip pliers	 (N) Fiorentini special socket
 (O) Fiorentini special tool		

Type	DN	50-75	100-125	160	250
A	Ch.	17-19-20	17-19-20	8-10-13-17 19-24-27-30-32	8-10-13-17 19-24-27-30-32
B	L.	300			
D	es. Ch.	10-26-27	10-26-27	40	46 (DN40)-50 (DN50)
E	Ch.	3	3		
F	es. Ch.	4	4	4-19	4-19
L	Cod	7999099			

DIVAL

Type	DN	50-75	100-125	160	250
A	Ch.	8-10-14 17-19-20	8-10-14 17-19-20	8-10-13-14-17 19-20-24-27-30-32	8-10-13-14-17-19 20-24-27-30-32
B	L.	300			
D	Ch.	10-13-26-27	10-13-26-27	10-13-27-27-32	13-27-46 (DN40)-50 (DN50)
E	Ch.	3	3		
I	L.	6.5 x 100			
L	Cod	7999099			
F		4	4	4-19	4-19

DIVAL + LA/..

9.0 LIST OF RECOMMENDED SPARES

DIVAL 160-250 PRESSURE REGULATOR

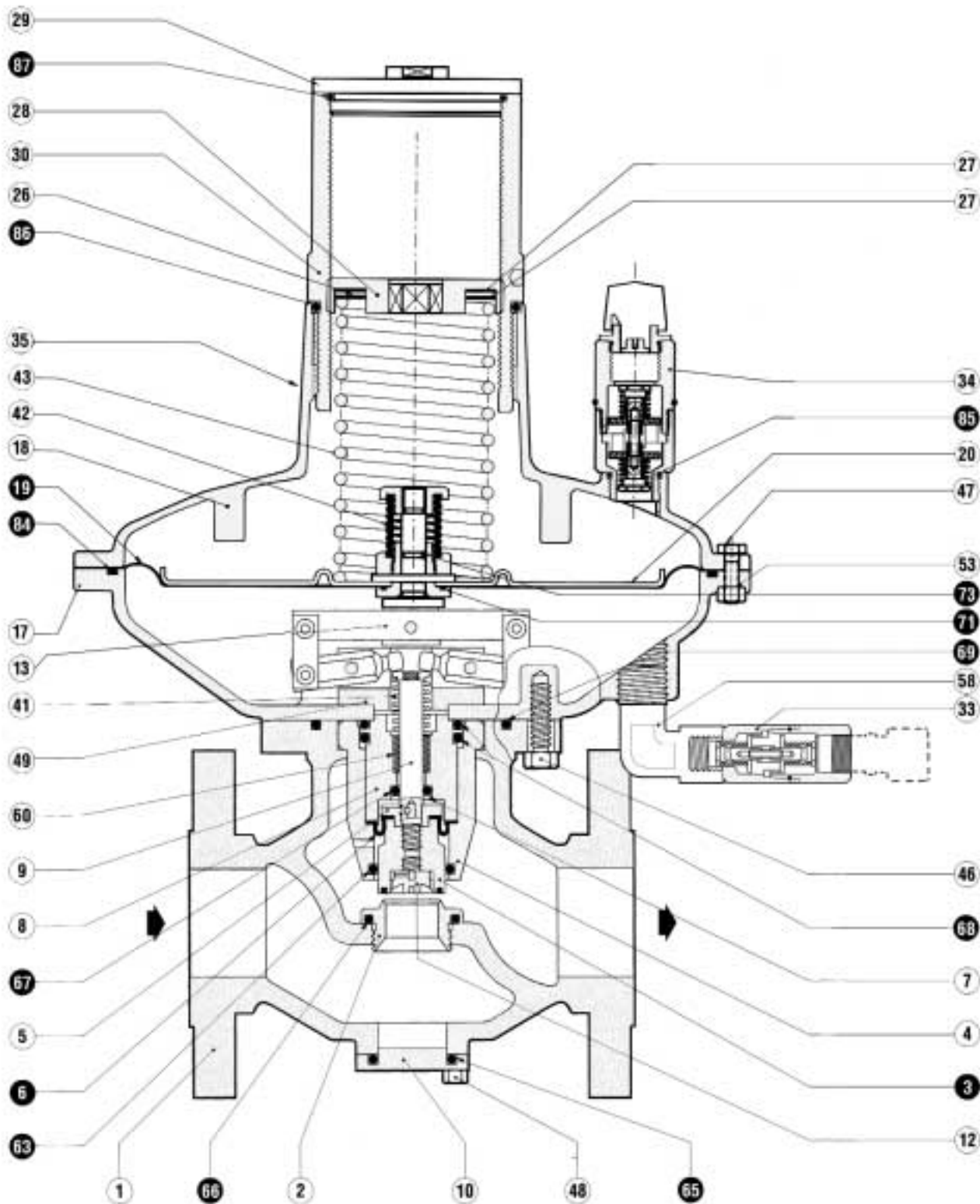

DIVAL 160
COVER Ø 275

VERSIONS

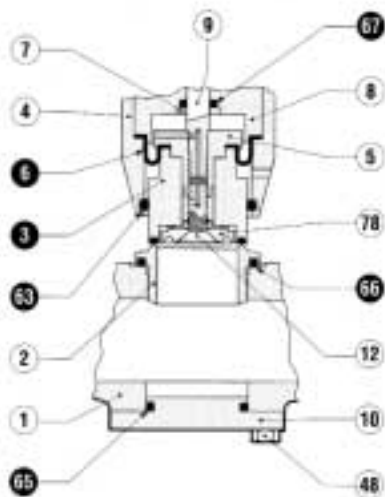

DIVAL 160

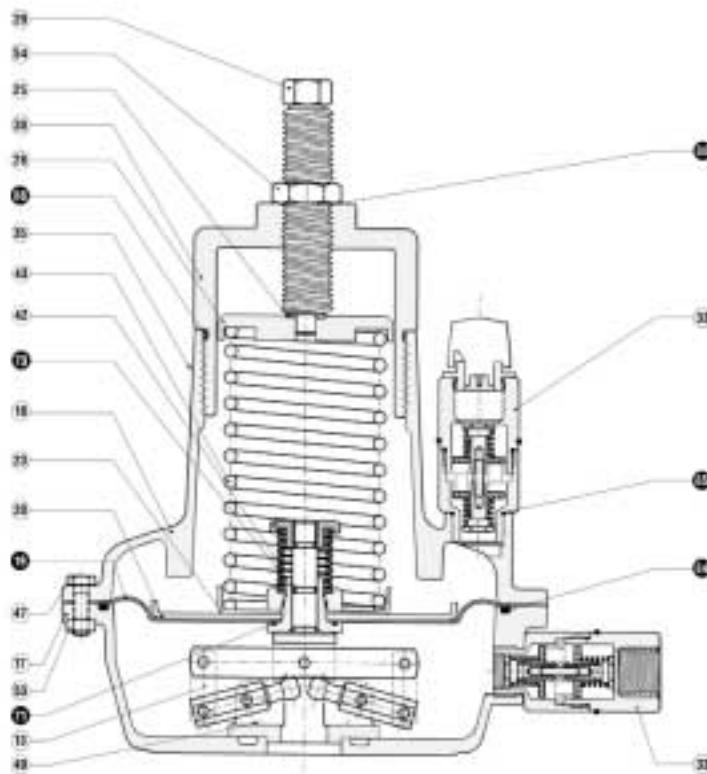

COVER Ø 195

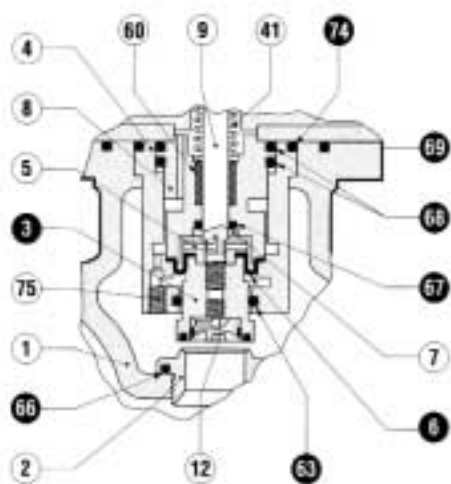

DIVAL 160 MONITOR

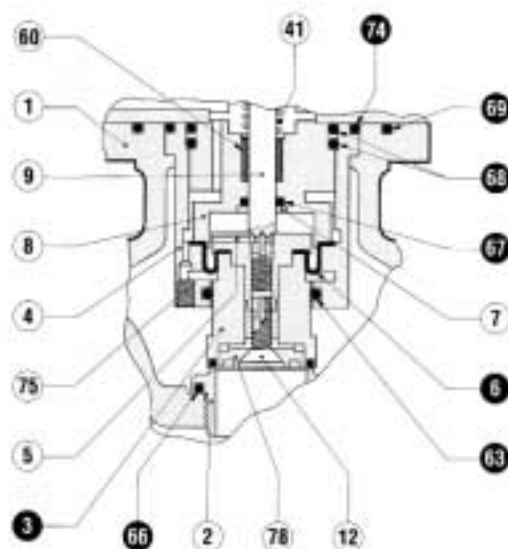

DIVAL 250 MONITOR

DIVAL 160-250	POS.	DESCRIPTION	N. OF PIECES
	3	Obturator	1
	°6	Diaphragm	1
	19*	Diaphragm	1
	60	Guide ring	1
	63	O. Ring (only ø275)	1
	64	O. Ring	1
	65	O. Ring	1
	66	O. Ring	1
	67	O. Ring	1
	68	O. Ring	2
	69	O. Ring	1
	71	O. Ring	1
	73	O. Ring	1
	74	O. Ring	1

° BATCH:

ø 195= T.N. 042

ø 275= BP= T.N. 045
MP= T.N. 042

*** DIAPHRAGM THICKNESS:**

ø 195= mm 1,1

ø 275= BP= mm 0,38
MP= mm 1,1

DIVAL 50-75-100-125 PRESSURE REGULATOR

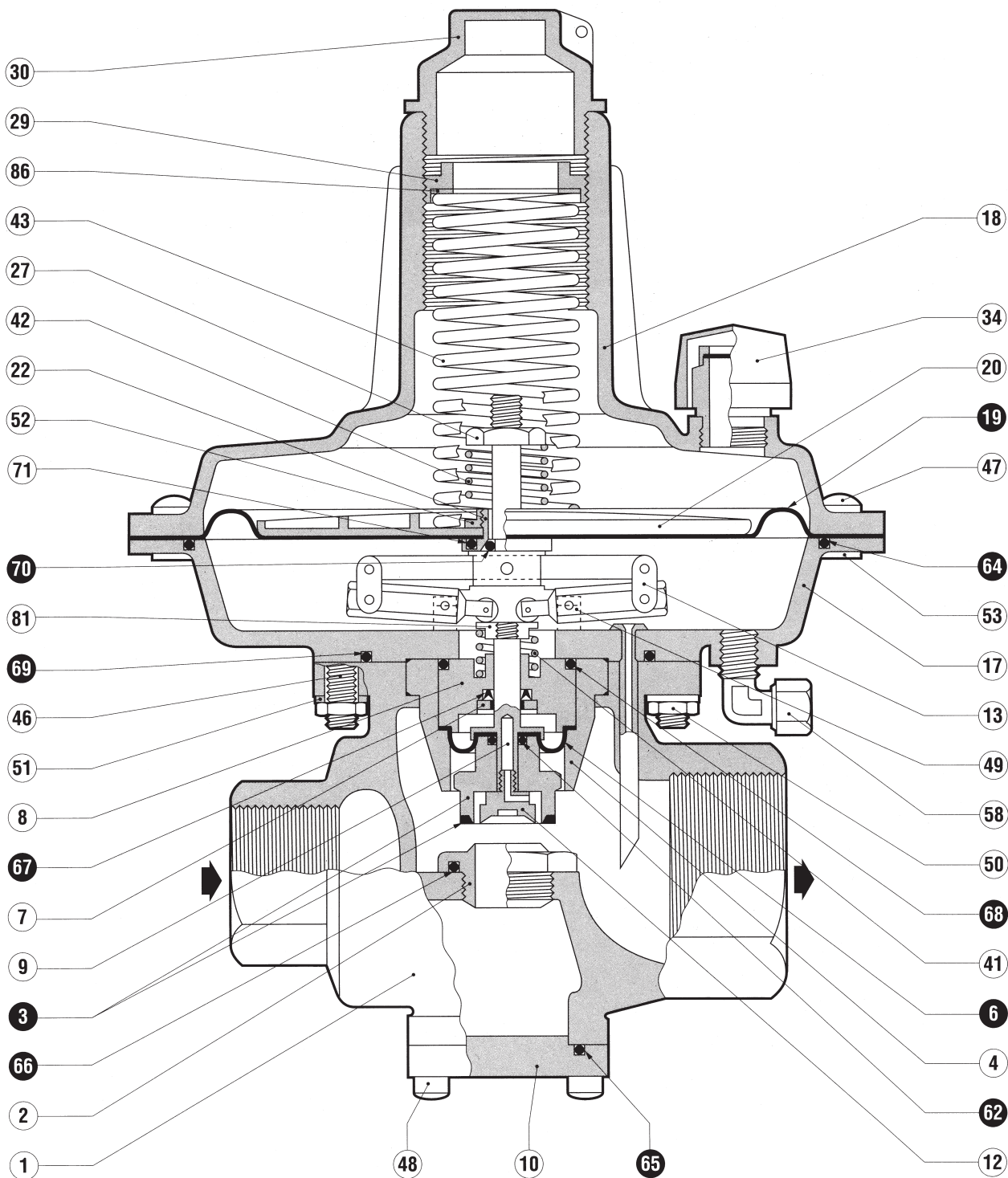

DIVAL 50-75BP
DIVAL 100-125BP

VERSIONS

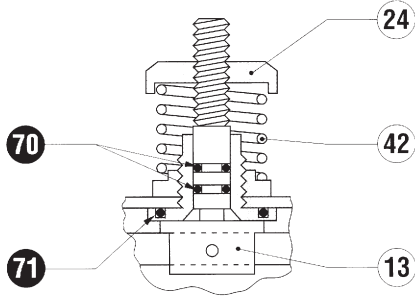

RELIEF VALVE CUT OFF

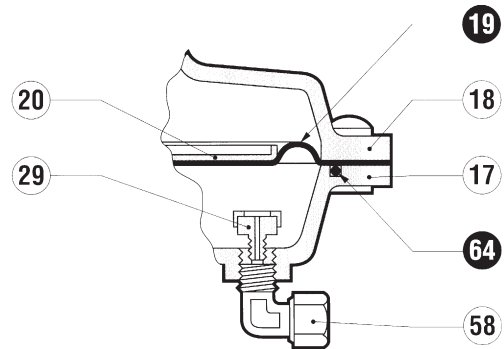

DIVAL 50-75MP - 100-125MP

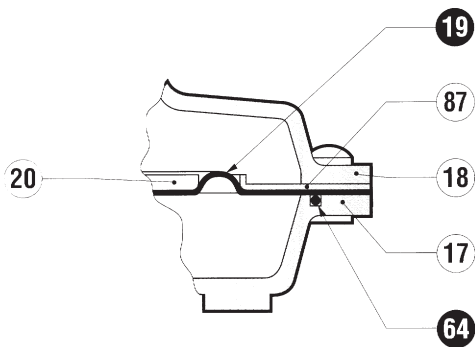

DIVAL 50-75-100-125 TR

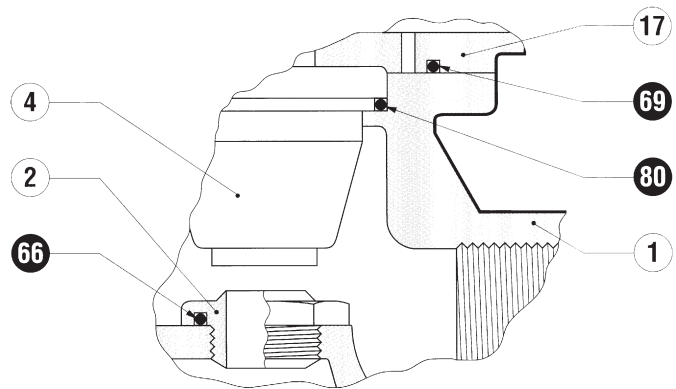

IN-LINE MONITOR

	POS.	DESCRIPTION	N. OF PIECES
DIVAL 50-75-100-125	3	Obturator	1
	6	Diaphragm	1
	19	Diaphragm	1
	62	O. Ring	1
	64	O. Ring	1
	65	O. Ring	1
	66	O. Ring	1
	67	Sealing U-Ring	1
	68	O. Ring	1
	69	O. Ring	1
	70	O. Ring	1
	71	O. Ring	1
	80	O. Ring (for monitor)	1

LA/MP-LA/BP-LA/TR SLAM-SHUT

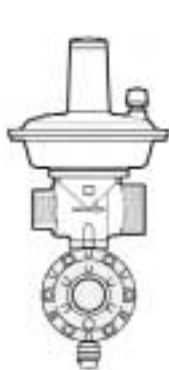

DIVAL 50-75-100-125



DIVAL 160-250

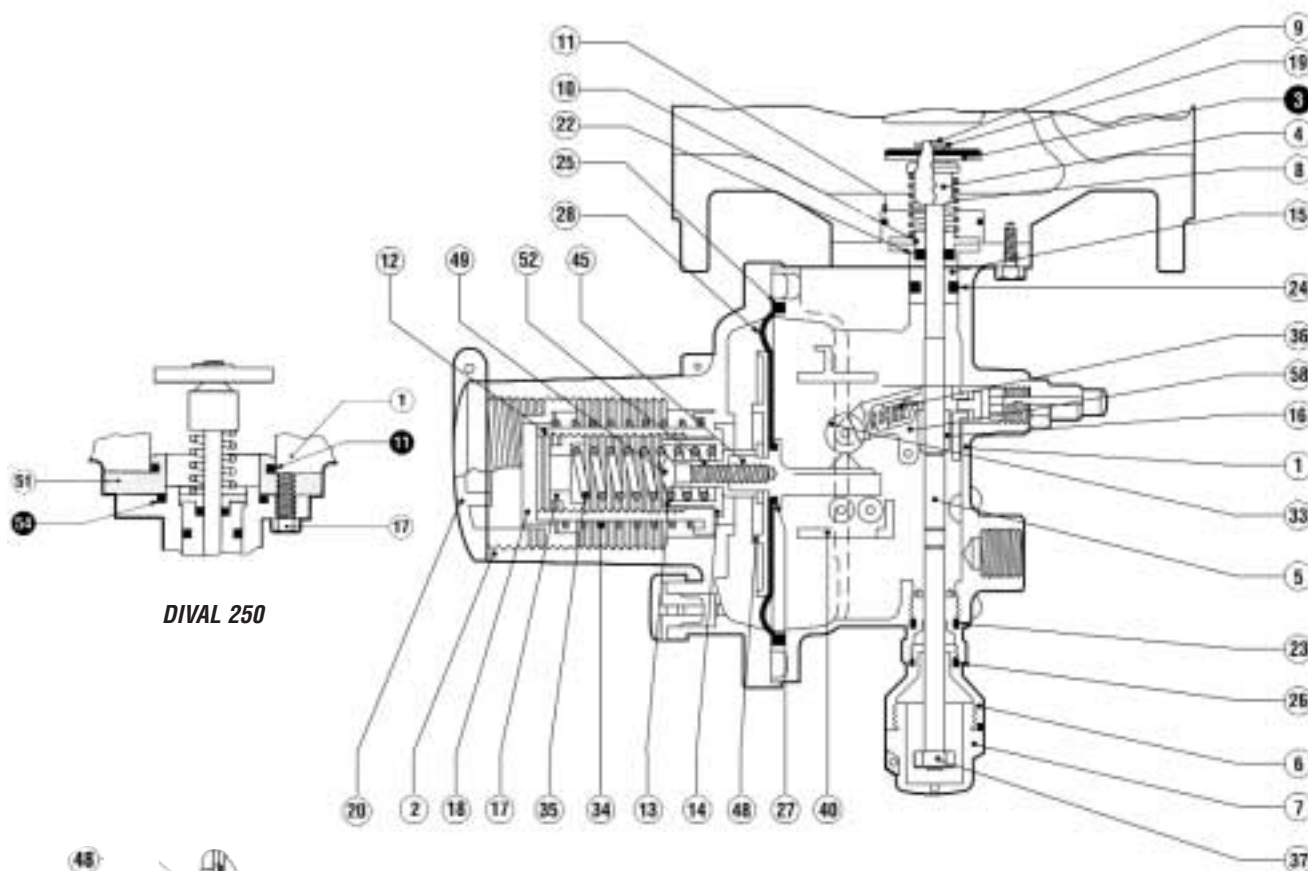

DIVAL 250

VERSION LA/TR

LA/

POS.	DESCRIPTION	N. OF PIECES
3	Obturator	1
21	Guide ring	1
22	O. Ring	1
23	O. Ring	1
24	O. Ring	1
25	U. Ring	1
26	O. Ring	1
28	Diaphragm	1
54	O. Ring	1
64	O. Ring	1

WHEN ORDERING SPARE PARTS, PLEASE SPECIFY:

FOR REGULATOR

Type of regulator

Dne (inlet nominal diameter)

Pe (inlet pressure)

Pa (outlet pressure)

Works no. (Serial no.)

Year of manufacture

Type of fluid used

Type of head for slam-shut (LA-LA/MP-LA/TR)

The no. of the part (position no.)

Quantity desired

The data are not binding. We reserve the right to make modifications without prior notice.

Pietro Fiorentini s.p.A.

OFFICES:

I-20124 MILANO

Italy - Via Rosellini, 1 - Phone +39.02.6961421 (10 linee a.r.) - Fax +39.02.6880457
E-mail: sales@fiorentini.com

I-36057 ARCUGNANO (VI)

Italy - Via E. Fermi, 8/10 - Phone +39.0444.968511 (10 linee a.r.) - Fax +39.0444.960468
E-mail: arcugnano@fiorentini.com

I-80049 SOMMA VESUVIANA (NA)

Italy - Via Cupa Fasano, 80 - Phone +39.081.8991965 - Fax +39.081.8991915
E-mail: napoli@fiorentini.com

SPARE PARTS AND AFTER-SALES SERVICE:

I-36057 ARCUGNANO (VI)

Italy - Via E. Fermi, 8/10 - Phone +39.0444.968511 (10 linee a.r.) - Fax +39.0444.968513 • E-mail: service@fiorentini.com

IMPAGINAZIONE E STAMPA
A CURA DI

Edigraf

MONTECCHIO MAGGIORE (VI)
FEBBRAIO 2003

Redazione a cura di: Pietro Bottari
Copyright © 2003 - Pietro Fiorentini S.p.A.